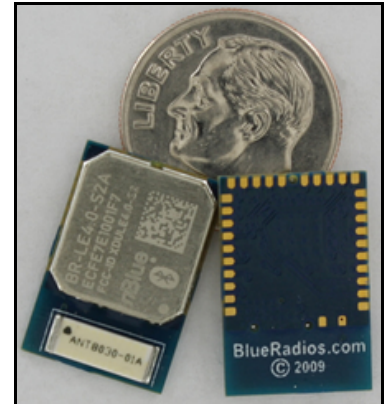

Bluetooth® 4.0 Low Energy Single Mode Class 1 SoC Module**nBlue™ BR-LE4.0-S2A (CC2540)**

● **AT HOME. AT WORK. ON THE ROAD. USING BLUETOOTH LOW ENERGY WIRELESS TECHNOLOGY MEANS TOTAL FREEDOM FROM THE CONSTRAINTS AND CLUTTER OF WIRES IN YOUR LIFE.**

- FCC, IC, CE, RoHS, and Bluetooth® 4.0 Certified ISM 2.4GHz module.
- Utilizes the TI CC2540 SoC with 256K Flash, 8K RAM.
- Over 150 meter (500 ft) line of site (LOS) distance with integrated antenna.
- Can be externally controlled via simple ASCII AT commands over the UART or programmed with custom applications embedded in the module.
- Available embedded *Bluetooth* Protocols and Profiles include: GAP, GATT, SMP, ATT, L2CAP, BAS, BLP, BLS, DIS, FMP, ANP, HIDS, HOGP, HID, HTP, HTS, HRP, HRS, IOP, IAS, LLS, PASP, PXP, SCPP, SCPS, TIP, TPS, and BRSP.
- The BR-LE4.0-S2 is identical to the BR-LE4.0-S3 with the exception of a USB controller replacing the I2C of the S3. In addition, the S2 provides a higher maximum output power.

**FEATURES**

- Integrated AT.s command stack for external control via UART or RF, with master/slave support and serial (BRSP) and battery (BAS) profiles. BRSP allows the user to stream data over LE similar to the way SPP works on Classic *Bluetooth* devices, but at a much lower maximum data rate.
- Available AT.e SDK for custom embedded applications on the module with approximately 130kB Flash and 2.5kB RAM available to the client application.
- UART (2 or 4 wire with CTS/RTS, 9600 to 460.8K baud), SPI, and USB data interfaces.
- 12-Bit ADC with 8 channels, RTC, battery monitor, temperature sensor, watchdog timer.
- Software adjustable transmitter power (-23dBm to 4dBm) for short to long range applications.
- Very low power consumption: *27mA 0dB TX, RX down to 19.6mA, .9uA sleep w/timer, and 0.4uA deep sleep.* Compatible with TI TPS62730 step down converter which can extend battery life by up to 20%.
- Secure and robust communication link:
 - ✓ FHSS (Frequency Hopping Spread Spectrum)
 - ✓ 24-bit CRC Error correction for guaranteed packet delivery
 - ✓ AES-128 bit encryption using CCM for encryption and authentication of packets.
- Firmware updates Over-the-Air (OTA) or over two wire UART interface.
- Modules easily configured to advertise as iBeacons to support immediate, near, and far proximity ranges.
- Free iOS & Android libraries and applications.

FIRMWARE OPTIONS

1. AT.s Command Set for external control via UART or RF.
2. AT.e SDK for custom embedded applications, which requires the IAR Systems Compiler.

APPLICATIONS

- Telemedicine / Telehealth
- Medical Patient Monitoring
- Human Interface Devices (Keyboard, Mouse, Remote control)
- Sports and leisure equipment
- Mobile phone accessories
- Remote controls
- Consumer Electronics
- Remote monitoring and control
- Health Care and Medical
- Smart Grid
- Automated Meter Reading (AMR)
- Home/Building Automation
- Machine-to-Machine (M2M)
- Wireless Sensor Networks
- Wireless Alarms and Security
- Lighting and HVAC control
- Proximity and out of range detection (iBeacon)

LOW ENERGY VS CLASSIC BLUETOOTH

- Broadcast support
- Connectionless always off technology
- Proximity and out of range detection
- 10 msec. connect time and low data latency
- First low power wireless technology standard

Bluetooth Low Energy, part of *Bluetooth* Ver. 4.0, specifies two types of implementation: **single** mode and **dual** mode. Single mode chips implement the low energy specification and consume just a fraction of the power of classic *Bluetooth*, allowing the short-range wireless standard to extend to coin cell battery applications for the first time. Dual mode chips combine low energy with the power of classic *Bluetooth* and are likely to become a de facto feature in almost all new *Bluetooth* enabled cellular phones and computers. Single mode *Bluetooth* 4.0 Low Energy is **NOT** backwards compatible with previous *Bluetooth* standards. Dual mode *Bluetooth* 4.0 Low Energy is backwards compatible but is not practical for low power devices but targeted to gateway products.

An **nBlue** single mode module communicating over BLE once a second consumes ~30µA on average. To put this in perspective, 30µA corresponds to 330 days of battery life using a CR2032 coin cell. BLE is not recommended for data streaming applications but is ideal for efficient short (20 byte or less) packet bursts.

In LE, GAP defines four specific roles: Broadcaster, Observer, Peripheral, and Central. A device may support multiple LE GAP roles provided that the underlying Controller supports those roles or role combinations. However, only one LE GAP role may be supported at a given time. The **Broadcaster** role is optimized for transmitter only applications. Devices supporting the broadcaster role use advertising to broadcast data. The broadcaster role does not support connections. The **Observer** role is optimized for receiver only applications. Devices supporting the observer role are the complementary device for a broadcaster and receives broadcast data contained in advertisements. The observer role does not support connections. The **Peripheral** role is optimized for devices that support a single connection and are less complex than central devices. Devices supporting the peripheral role only require Controllers that support the Controller's slave role. The **Central** role supports multiple connections and is the initiator for all connections with devices in the peripheral role. Devices supporting the central role require a Controller that supports the Controller's master role and generally supports more complex functions compared to the other LE GAP roles.

SPECIFICATIONS SUMMARY

Operating Conditions Summary

Item	Specifications
Supply voltage (VDD)	2.0-3.6 V
VDD ripple	100 mV Max
Max voltage on any pin	VDD + .3 V (Not 5V Tolerant)
Ambient Temperature Range	-40 – 85 °C

Current Consumption Summary

Measurements done at TA = 25°C, VDD = 3 V

Item	Specifications	Specifications w/ TPS62730
Power Mode 3 (120µs Wake-Up)	0.4 µA	0.4 µA
Power Mode 2 (120µs Wake-Up)	0.9 µA	0.9 µA
Power Mode 1 (4µs Wake-Up)	235 µA	235 µA
Low MCU Activity	6.7 mA	6.7 mA
RX Standard Gain	19.6 mA	15.8 mA
RX High Gain	22.1 mA	17.8 mA
TX -23 dBm	21.1 mA	16.5 mA
TX -6 dBm	23.8 mA	18.6 mA
TX 0 dBm	27 mA	21 mA
TX 4 dBm	31.6 mA	24.6 mA

RF Specifications Summary

Item	Specifications
Frequency	2402 – 2480 MHz in 2 Mhz steps
Data Rate and Modulation	1 Mbps, GFSK
Number of Channels	40: 37 data / 3 advertising (0,12,39)
Receive Sensitivity (w/chip antenna)	-95/-89 dBm
Output Power	-23 to 4 dBm
Link Budget	Up to 99dB
RX/TX Turnaround	150 us

DIMENSIONS

BR-LE4.0-S2N (Without Antenna, SMD Output) – 11.8 x 12.6 x 1.9 mm

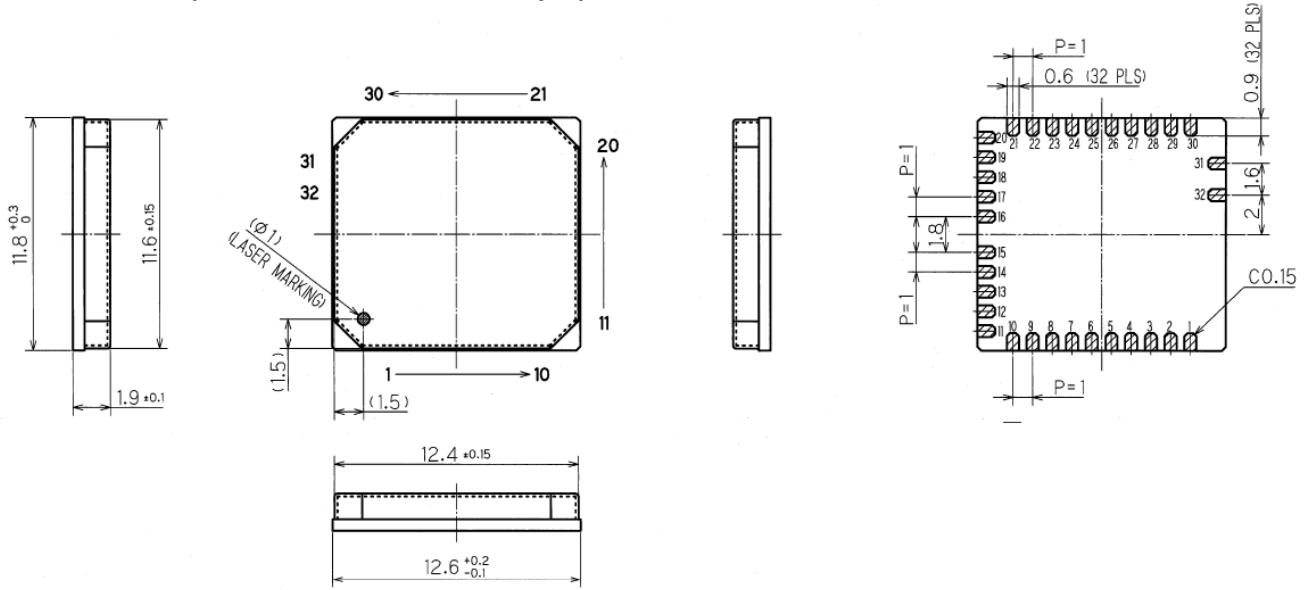

BR-LE4.0-S2A (With 2 dBi TDK ANT8030-2R4-01 Antenna) – 11.8 x 17.6 x 1.9 mm

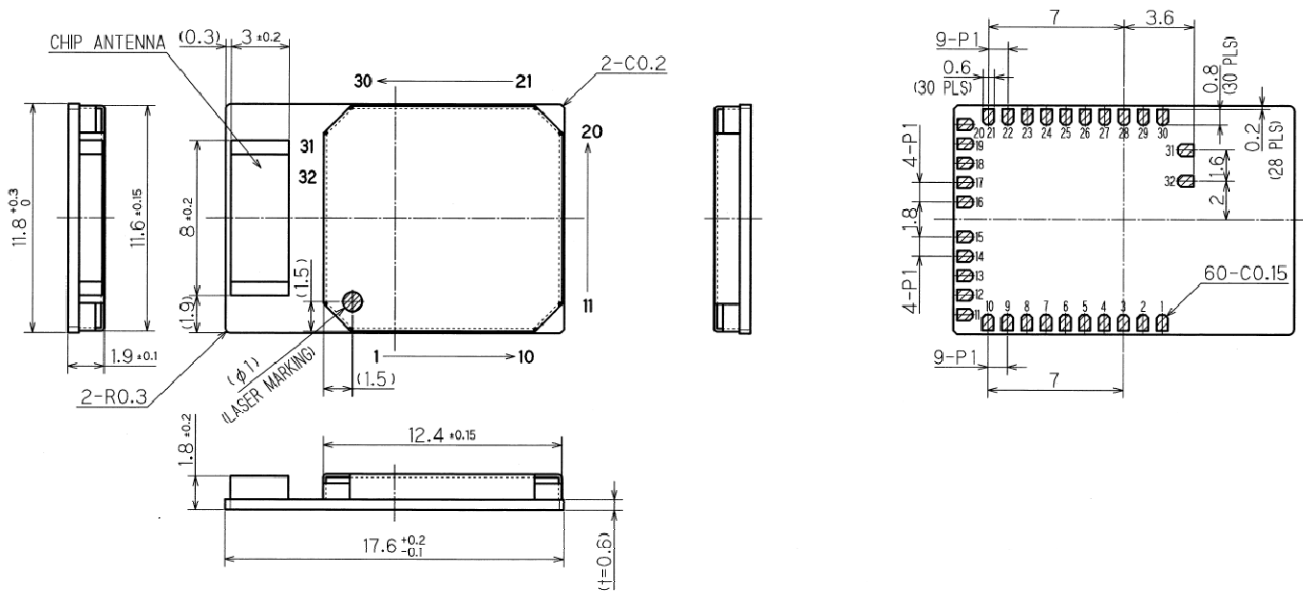

Units: mm

STANDARD LAND DIMENSIONS (WITH ANTENNA)

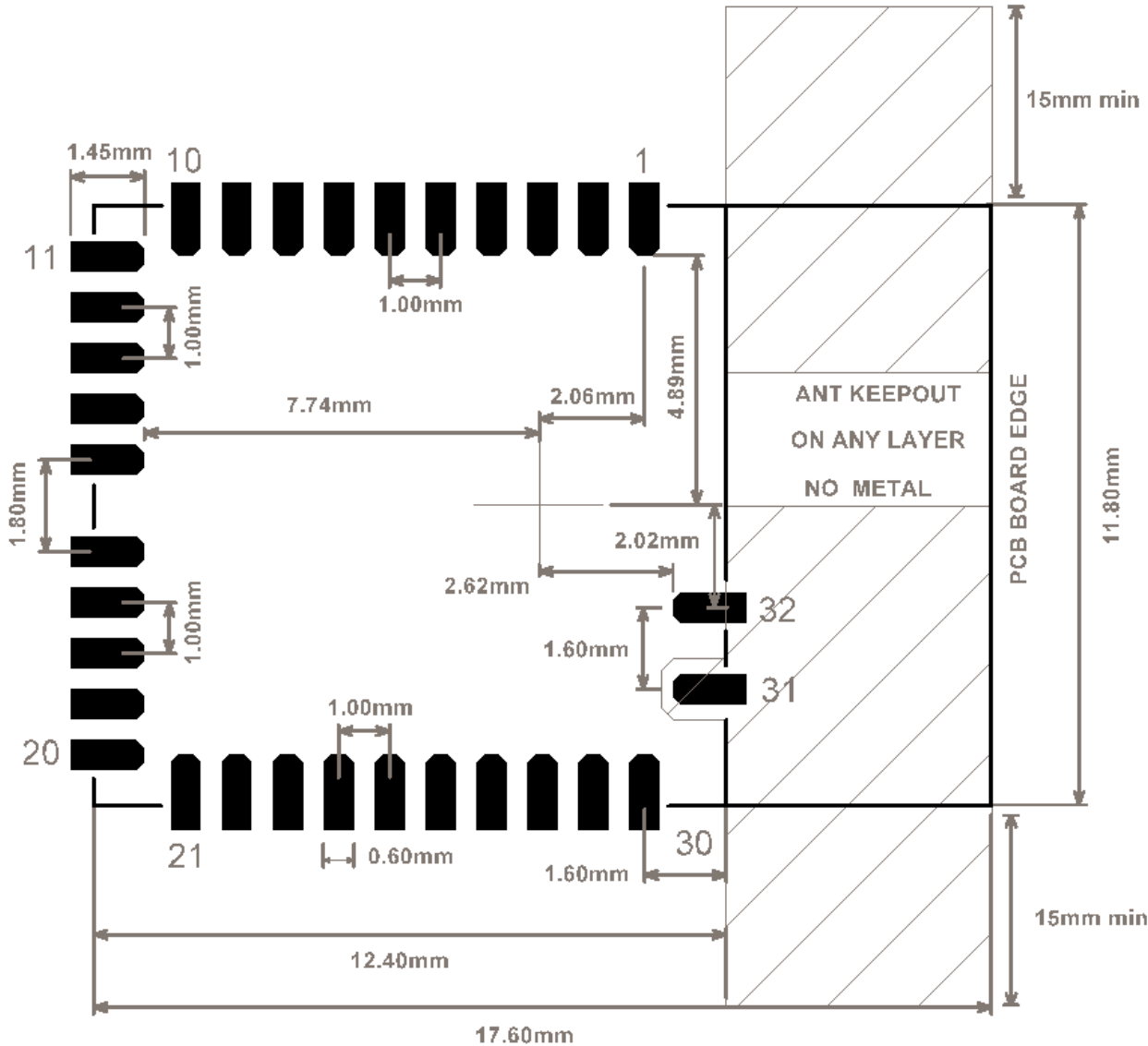

Note: Radio requires a RF ground plane on the rest of the Printed Circuit Board (PCB) area. This can be located on any layer of the PCB. Extend the RF ground plane parallel to module pins 31 and 32 the entire length of your board. Connect all ground pins and do not notch the ground plane around the module. Bottom of module is grounded so be careful of vias or conductive traces located under the modules that are not soldered masked to prevent shorting. Keep metallic components, connectors, copper traces, internal layers, and ground planes away from the antenna area in 3D space!

PINOUT

Pin	Pin Name	Pin	Pin Name
1	GND	17	USB_DP
2	NC	18	USB_DM
3	RESET (Active Low)	19	PIO_14
4	ADC_1	20	GND
5	SPI_MISO	21	ADC_0
6	SPI_CSB	22	PIO_9
7	SPI_CLK	23	PIO_2 (20mA)
8	SPI_MOSI	24	PIO_5 (20mA)
9	VDD (2.0-3.6V)	25	PIO_6
10	GND	26	PIO_3
11	UART_CTS	27	PIO_8
12	UART_RTS	28	PIO_4 (DD)
13	UART_TX	29	PIO_7 (DC)
14	UART_RX	30	GND
15	USB_VBUS	31	NC (RF Test Antenna)
16	USB_GND	32	NC (RF Test Ground)

DEBUGGING

PIO_4 and PIO_7 also function as the Debug Data (DD) and Debug Clock (DC) lines, allowing the modules to be connected to a TI CC-Debugger for debugging and programming. See the CC Debugger User's Guide for more information: <http://www.ti.com/tool/cc-debugger>

An nBlue Interace Board (IB) is also available and allows the user to debug, program, update firmware and have UART communications with any of the nBlue modules through a single or double row 10 pin header. See the nBlue Module User's Guide for more information.

A CC-DEBUGGER is only needed for writing a custom application for a module and not using the AT.s command set, AT.s firmware can be updated without a debugger.

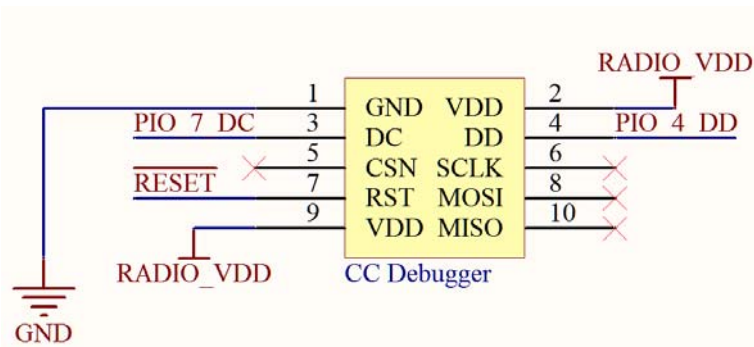

ORDERING INFORMATION

Pricing and ordering information can be found at:

http://www.blueradios.com/orderinfo_new.htm

PART NUMBER

BR-LE4.0-S2#

BR = BlueRadios

LE = Low Energy

4.0 = *Bluetooth* LE version

S = Single Mode

2 = Class 1 SoC Module +150 meter (CC2540)

= A (Antenna)

= U (U.FL RF Connector) built to order, not a stock item, 5K minimum

= N (No Antenna, SMD Output) built to order, not a stock item, 5K minimum

<u>Part Number</u>	<u>Description</u>
1. BR-LE4.0-S2A	<i>Bluetooth</i> Low Energy v4.0 Single Mode with Antenna
2. BR-LE4.0-S2U	<i>Bluetooth</i> Low Energy v4.0 Single Mode with U.FL RF Connector
3. BR-LE4.0-S2N	<i>Bluetooth</i> Low Energy v4.0 Single Mode No Antenna, SMD Output

STANDARD PACKAGING

Tape and Reel (T&R) 500 or 1,000 piece 340mm x 25mm reel sizes

DEVELOPMENT KIT (BR-EVAL-LE4.0-S2A)

Development kit available containing everything required to set up a connection quickly and evaluate range and performance of the BR-LE4.0-S2A: http://www.blueradios.com/hardware_EVAL-LE4.0-S2.htm

CUSTOM FIRMWARE

The AT.s command interface can be modified for high volume customers and custom embedded software development is available upon request

ADDITIONAL DOCUMENTATION

Complete OEM documentation can be found at: <http://www.blueradios.com/forum>. Requires proof of purchase.