



R&TTE (1999/5/EC) Directive
ETSI EN 300 328 v1.6.1: 2004
TEST REPORT

FOR

Product Name: Bluetooth Module

Brand Name: Mitsumi

Model Name: WML-C46NBR, WML-C46NHR,
WML-C46ABR, WML-C46AHR

Model Difference: N: external antenna ,
A: internal antenna
B:BCSP; H:UART

Report No.: EF/2006/10011

Issue Date: Apr. 24, 2006

Prepared for MITSUMI ELECTRIC CO., LTD.
2-11-2, Tsurumaki, Tama-shi, Tokyo Japan

Prepared by SGS Taiwan Ltd.
No. 134, Wu Kung Rd., Wuku Industrial
Zone, Taipei County, Taiwan.



Note: This report shall not be reproduced except in full, without the written approval of SGS Taiwan Ltd. This document may be altered or revised by SGS Taiwan Ltd. personnel only, and shall be noted in the revision section of the document.

The results shown in this test report refer only to the sample(s) tested unless otherwise stated. This test report cannot be reproduced, except in full, without prior written permission of the Company.

VERIFICATION OF COMPLIANCE

Applicant: MITSUMI ELECTRIC CO., LTD.
 2-11-2, Tsurumaki, Tama-shi, Tokyo Japan

Equipment Under Test: Bluetooth Module

Brand Name: Mitsumi

Model No.: WML-C46NBR, WML-C46NHR,
 WML-C46ABR, WML-C46AHR

Model Difference: N: external antenna ,
 A: internal antenna
 B: BCSP; H: UART



File Number: EF/2006/10011

Date of test: Apr. 17, 2006 ~ Apr. 21, 2006

Date of EUT Received: Apr. 16, 2006

APPLICABLE STANDARDS	
STANDARD	TEST RESULT
ETSI EN 300 328 V1.6.1: 2004	Complied

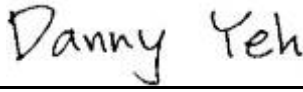
The above equipment was tested by SGS Taiwan Ltd. for compliance with the requirements set forth in the European Standard ETSI EN 300 328 V1.6.1: 2004 under R&TTE Directive 1999/5/EC Class I, Sub-Class 21. The results of testing in this report apply to the product system that was tested only. Other similar equipment will not necessarily produce the same results due to production tolerance and measurement uncertainties.

Test By:	 Danny Yeh	Date	Apr. 24, 2006
Prepared By:	 Cathy Kuo	Date	Apr. 24, 2006
Approved By:	 Vincent Su	Date	Apr. 24, 2006

The results shown in this test report refer only to the sample(s) tested unless otherwise stated. This test report cannot be reproduced, except in full, without prior written permission of the Company.

Version

Version No.	Date
00	Apr. 24, 2006

The results shown in this test report refer only to the sample(s) tested unless otherwise stated. This test report cannot be reproduced, except in full, without prior written permission of the Company.

TABLE OF CONTENTS

PAGE

1.	DESCRIPTION OF EQUIPMENT UNDER TEST (EUT)	5
2.	DESCRIPTION OF TEST MODES	6
3.	GENERAL DESCRIPTION OF APPLIED STANDARDS	6
4.	TEST FACILITY	6
5.	SUPPORT EQUIPMENT	7
6.	ETSI EN 300 328 SUBCLAUSE 4.3.1 EQUIVALENT ISOTROPIC RADIATED POWER	8
7.	ETSI EN 300 328 SUBCLAUSE 4.3.2 MAXIMUM SPECTRAL POWER DENSITY	11
8.	ETSI EN 300 328 SUBCLAUSE 4.3.3 FREQUENCY RANGE	12
9.	ETSI EN 300 328 SUBCLAUSE 4.3.4 TRANSMITTER SPURIOUS EMISSIONS.....	14
10.	ETSI EN 300 328 SUBCLAUSE 4.3.5 RECEIVER SPURIOUS EMISSIONS	21
	PHOTOGRAPHS OF SET UP.....	25
	PHOTOGRAPHS OF EUT	27

The results shown in this test report refer only to the sample(s) tested unless otherwise stated. This test report cannot be reproduced, except in full, without prior written permission of the Company.

1. DESCRIPTION OF EQUIPMENT UNDER TEST (EUT)

Type of equipment	Bluetooth Module
Brand Name	Mitsumi
Model Name	WML-C46NBR, WML-C46NHR, WML-C46ABR, WML- C46AHR
Model Difference	N: external antenna , A: internal antenna B:BCSP; H:UART
Power Supply	3.3Vdc
Transmit Power	2.65 dBm E.I.R.P.
Frequency Range	2.402GHz – 2.480GHz
Modulation Technique	Frequency Hopping Spread Spectrum (FHSS) (GFSK)
Number of Channels	79
Dwell Time	<= 0.4s
Operating Mode	Point-to-Point
Data Rate	741 Kbps (Highest Mode)
Antenna Type	Chip Antenna
Antenna Gain	2.0 dBi

The results shown in this test report refer only to the sample(s) tested unless otherwise stated. This test report cannot be reproduced, except in full, without prior written permission of the Company.

2. DESCRIPTION OF TEST MODES

The EUT has been tested under Operating and standby condition. And used to control the EUT for staying in continuous transmitting and receiving mode is programmed. Channel 0, 39 and 78 with 741kbps highest data rate are chosen for testing.

3. GENERAL DESCRIPTION OF APPLIED STANDARDS

The EUT According to the Specifications, it must comply with the requirements of the following standards:

ETSI EN 300 328 v1.6.1 : 2004 – Electromagnetic compatibility and Radio spectrum Matters (ERM) ; Wideband transmission systems; Data transmission equipment operating in the 2.4GHz ISM band and using wide band modulation techniques:

4. TEST FACILITY

SGS Taiwan Ltd.

No. 134, Wu Kung Rd., Wuku Industrial Zone, Taipei County, Taiwan.

A 11m*6m*6m fully anechoic chamber was used for the radiated spurious emissions test.

5. SUPPORT EQUIPMENT

Fig. 5-1 Configuration of Tested System

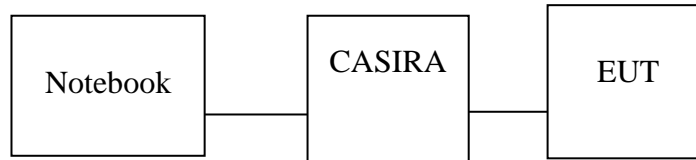

Table 5-1 Equipment Used in Tested System

Item	Equipment	Mfr/Brand	Model/ Type No.	FCC ID	Series No.	Data Cable	Power Cord
1.	Notebook	IBM	T40	99HCYF4	R33026	Un-shield	Un-shield
2.	CASIRA	CSR	BCES301199/1	7383070403	CASIRA	Un-shield	Un-shield
3.	Test software	CSR	Bluesuit 1.21	N/A	N/A	N/A	N/A

The results shown in this test report refer only to the sample(s) tested unless otherwise stated. This test report cannot be reproduced, except in full, without prior written permission of the Company.

6. ETSI EN 300 328 SUBCLAUSE 4.3.1 EQUIVALENT ISOTROPIC RADIATED POWER

6.1. Limit:

ETSI EN 300 328 Subclause 4.3.1.2: The equivalent isotropic radiated power shall be equal to or less than -10 dBW (100 mW) e.i.r.p. This limit shall apply for any combination of power level and intended antenna assembly.

6.2. Measurement Equipment Used:

Conducted Emission Test Site					
EQUIPMENT TYPE	MFR	MODEL NUMBER	SERIAL NUMBER	LAST CAL.	CAL DUE.
Spectrum Analyzer	Agilent	E4446A	MY43360126	03/29/2006	03/28/2007
Spectrum Analyzer	Agilent	7405A	US41160416	06/28/2005	06/29/2006
Spectrum Analyzer	R&S	FSP 40	100034	11/09/2005	11/10/2006
Power Sensor	Anritsu	MA2490A	31431	06/28/2005	06/29/2006
Power Meter	Anritsu	ML2487A	6K00002070	06/28/2005	06/29/2006
Temperature Chamber	TERCHY	MHG-120LF	911009	11/11/2005	11/12/2006
Low Loss Cable	HUBER+SUHNER	SUCOFLEX 104PEA	N/A	N/A	N/A
Attenuator	Mini-Circuit	BW-S10W5	N/A	10/07/2005	10/06/2006
Attenuator	Mini-Circuit	BW-S6W5	N/A	10/07/2005	10/06/2006
Splitter	Agilent	11667B	N/A	09/23/2005	09/22/2006
Signal Generator	R&S	SMR40	100210	11/09/2005	11/10/2006
Signal Generator	Agilent	8648D	3847M00432	04/15/2006	04/14/2007
Diode Detector	Agilent	8471E	MY4224	N/A	N/A
AC Power Supply	APW-105N	887592	All Power	12/15/2005	12/14/2006

The results shown in this test report refer only to the sample(s) tested unless otherwise stated. This test report cannot be reproduced, except in full, without prior written permission of the Company.

6.3. Test Setup:

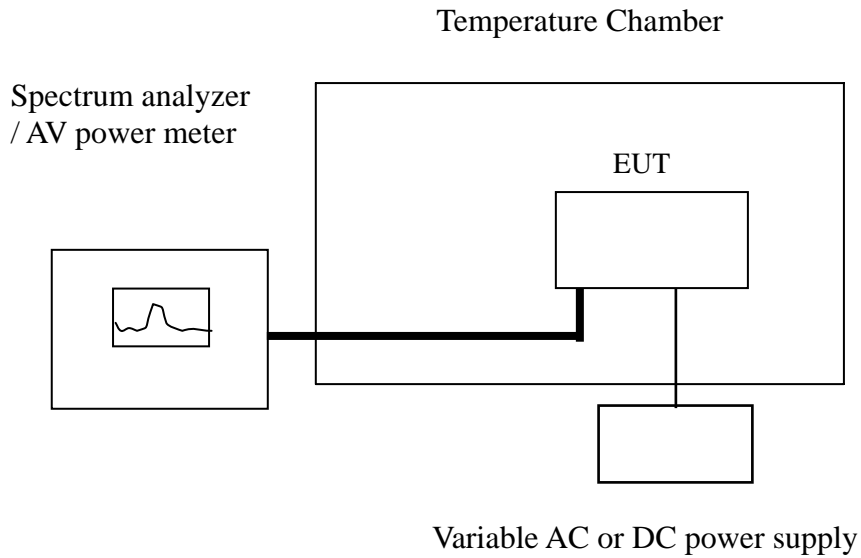

6.4. Test Procedure:

See subclause 5.3 of ETSI EN 300 328 for the test conditions

See Subclause 5.7.2.2 of ETSI EN 300 328 for conducted measurement method.

6.5. Equivalent Isotropic Radiated Power E.I.R.P. Test results:

Ambient temperature: 25 Relative humidity: 65 % Test Date: 04/17/2006

Duty Cycle measurement X: (Ton/Ton + Toff)

= 0.3357

Antenna assembly gain: 2 dBi

Cable Loss= 0.2 dB

$P = A (\text{Average Power}) + G + 10 \log (1/X)$

TEST CONDITIONS		TRANSMITTER POWER (dBm)		
		Lowest Frequency (CH Low)	Middle Frequency (CH Mid)	Highest Frequency (CH High)
Temp (-20)°C	Vmin 2.81 V	Pk = 2.64 dBm Av = -4.30 dBm	Pk = 2.04 dBm Av = -4.90 dBm	Pk = 1.73 dBm Av = -5.21 dBm
	Vmax 3.80 V	Pk = 2.65 dBm Av = -4.29 dBm	Pk = 2.03 dBm Av = -4.91 dBm	Pk = 1.71 dBm Av = -5.23 dBm
Temp (25)°C	Vnom 3.30 V	Pk = 1.34 dBm Av = -5.60 dBm	Pk = 0.81 dBm Av = -6.13 dBm	Pk = 0.82 dBm Av = -6.12 dBm
Temp (55)°C	Vmin 2.81 V	Pk = 0.54 dBm Av = -6.40 dBm	Pk = 0.00 dBm Av = -6.94 dBm	Pk = 0.13 dBm Av = -6.81 dBm
	Vmax 3.80 V	Pk = 0.59 dBm Av = -6.35 dBm	Pk = 0.01 dBm Av = -6.93 dBm	Pk = 0.14 dBm Av = -6.80 dBm
Limit		20dBm		
Measurement uncertainty		+ 0.28dB / - 0.30dB		

The results shown in this test report refer only to the sample(s) tested unless otherwise stated. This test report cannot be reproduced, except in full, without prior written permission of the Company.

7. ETSI EN 300 328 SUBCLAUSE 4.3.2 MAXIMUM SPECTRAL POWER DENSITY

7.1. Limit:

ETSI EN 300 328 Subclause 4.3.2.2: TFor wide band modulations other then FHSS (e.g. DSSS, OFDM, etc.), the maximum spectrum power density is limited to 10 mW per MHz e.i.r.p.

7.2. Measurement Equipment Used:

Same as section 6.2 in this report.

7.3. Test Setup:

Same as section 6.3 in this report.

7.4. Test Procedure:

See subclause 5.3 of ETSI EN 300 328 for the test conditions

See Subclause 5.7.2.3 of ETSI EN 300 328 for conducted measurement method.

7.5. Maximum Spectral Power Density Test results:

N/A, The device is FHSS modulation.

8. ETSI EN 300 328 SUBCLAUSE 4.3.3 FREQUENCY RANGE

8.1. Limit:

For all equipment the frequency range shall lie within the band 2,4 GHz to 2,4835 GHz ($f_L > 2.4\text{GHz}$ and $f_H < 2.4835\text{GHz}$).

8.2. Measurement Equipment Used:

Same as section 6.2 in this report.

8.3. Test Setup:

Same as section 6.3 in this report.

8.4. Test Procedure:

See subclause 5.3 of ETSI EN 300 328 for the test conditions

See Subclause 5.7.4.1 of ETSI EN 300 328 for conducted measurement method.

8.5. Frequency Range Test results:

Ambient temperature: 25

Relative humidity: 65 %

Test Date: 04/17/2006

TEST CONDITIONS		FREQUENCY (MHz)	
		Lowest	Highest
Tmax(-20)oC	V _{min} 2.81 V	2401.5530	2480.5120
	V _{max} 3.80 V	2401.5800	2480.4950
Tnom(25)oC	V _{nom} 3.30 V	2401.5230	2480.4720
Tnom(55)oC	V _{min} 2.81 V	2401.5630	2480.3950
	V _{max} 3.80 V	2401.5330	2480.3690
Measured frequencies (lowest and highest)		fL= 2401.5230 MHz	fH= 2480.5120 MHz
Limit		2400.0000 MHz	2483.5000 MHz
Measurement Uncertainty		+/- 120kHz	

The results shown in this test report refer only to the sample(s) tested unless otherwise stated. This test report cannot be reproduced, except in full, without prior written permission of the Company.

9. ETSI EN 300 328 SUBCLAUSE 4.3.4 TRANSMITTER SPURIOUS EMISSIONS

9.1. Limit:

The spurious emissions of the transmitter shall not exceed the values in tables 1 and 2 in the indicated bands.

Table 1: Transmitter limits for Narrowband Spurious emissions

Frequency Range	Limit when operating	Limit when in standby
30MHz to 1 GHz	-36 dBm	-57 dBm
above 1 GHz to 12.75 GHz	-30 dBm	-47 dBm
1.8 GHz to 1.9 GHz 5.15 GHz to 5.3 GHz	-47 dBm	-47 dBm

The above limit values apply to narrowband emissions, e.g. as caused by local oscillator leakage. The measurement bandwidth for such emissions may be as small as necessary to achieve a reliable measurement result.

Wideband emissions shall not exceed the values given in table 2.

Table 2: Transmitter limits for Wideband Spurious emissions

Frequency Range	Limit when operating	Limit when in standby
30MHz to 1 GHz	-86 dBm/Hz	-107 dBm/Hz
above 1 GHz to 12.75 GHz	-80 dBm/Hz	-97 dBm/Hz
1.8 GHz to 1.9 GHz 5.15 GHz to 5.3 GHz	-97 dBm/Hz	-97 dBm/Hz

9.2. Measurement Equipment Used:

EQUIPMENT TYPE	MFR	MODEL NUMBER	SERIAL NUMBER	LAST CAL.	CAL DUE.
Spectrum Analyzer	Agilent	E4446A	MY43360126	03/29/2006	03/28/2007
Spectrum Analyzer	Agilent	7405A	US41160416	06/28/2005	06/29/2006
Spectrum Analyzer	R&S	FSP 40	100034	11/09/2005	11/10/2006
Bilog Antenna	SCHWAZBECK	VULB9163	152	06/03/2005	06/02/2006
Horn antenna	Schwarzbeck	BBHA 9120D	309/320	08/16/2005	08/15/2006
Pre-Amplifier	HP	8447D	2944A09469	07/19/2005	07/18/2006

The results shown in this test report refer only to the sample(s) tested unless otherwise stated. This test report cannot be reproduced, except in full, without prior written permission of the Company.

Pre-Amplifier	HP	8494B	3008A00578	02/26/2006	02/25/2007
Signal Generator	R&S	SMR40	100210	02/09/2006	02/10/2007
Signal Generator	Agilent	8648D	3847M00432	04/15/2006	04/14/2007
Turn Table	HD	DT420	N/A	N.C.R	N.C.R
Antenna Tower	HD	MA240-N	240/657	N.C.R	N.C.R
Controller	HD	HD100	N/A	N.C.R	N.C.R
Low Loss Cable	HUBER+SUHNER	SUCOFLEX 104PEA-10M	10m	10/09/2005	10/08/2006
Low Loss Cable	HUBER+SUHNER	SUCOFLEX 104PEA-0.5M	0.5m	10/09/2005	10/08/2006
Site NSA	SGS	1166 chamber	N/A	11/17/2005	11/16/2006
Temperature Chamber	TERCHY	MHG-120LF	911009	10/14/2005	10/13/2006
Dipole Antenna	Schwarzbeck	VHAP	908/909	06/10/2005	06/11/2006
Dipole Antenna	Schwarzbeck	UHAP	891/892	06/10/2005	06/11/2006
Horn antenna	Schwarzbeck	BBHA 9120D	N/A	08/16/2005	08/15/2006

9.3. Test Setup:

9.3.1. Step 1. Field Strength Measurement

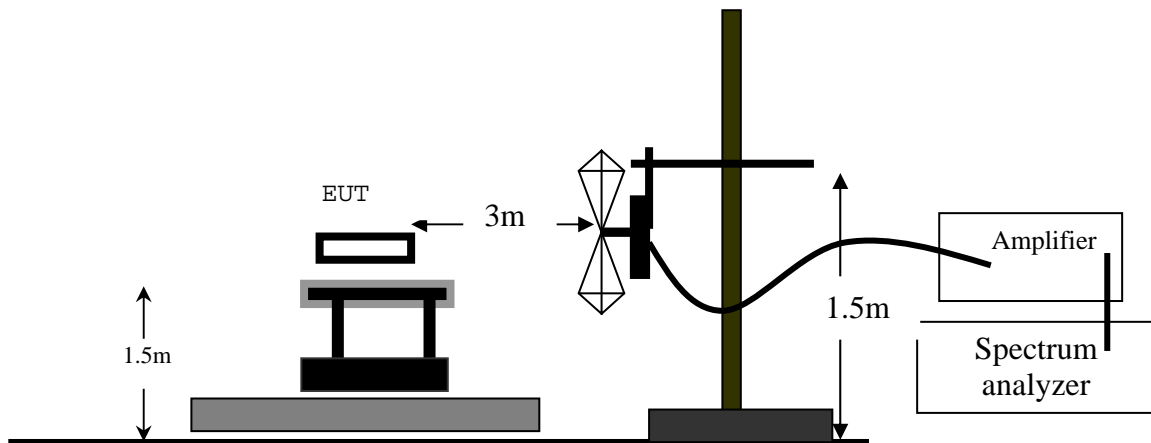

The results shown in this test report refer only to the sample(s) tested unless otherwise stated. This test report cannot be reproduced, except in full, without prior written permission of the Company.

9.3.2. Step 2. Substitution Measurement

Frequency Below 1GHz

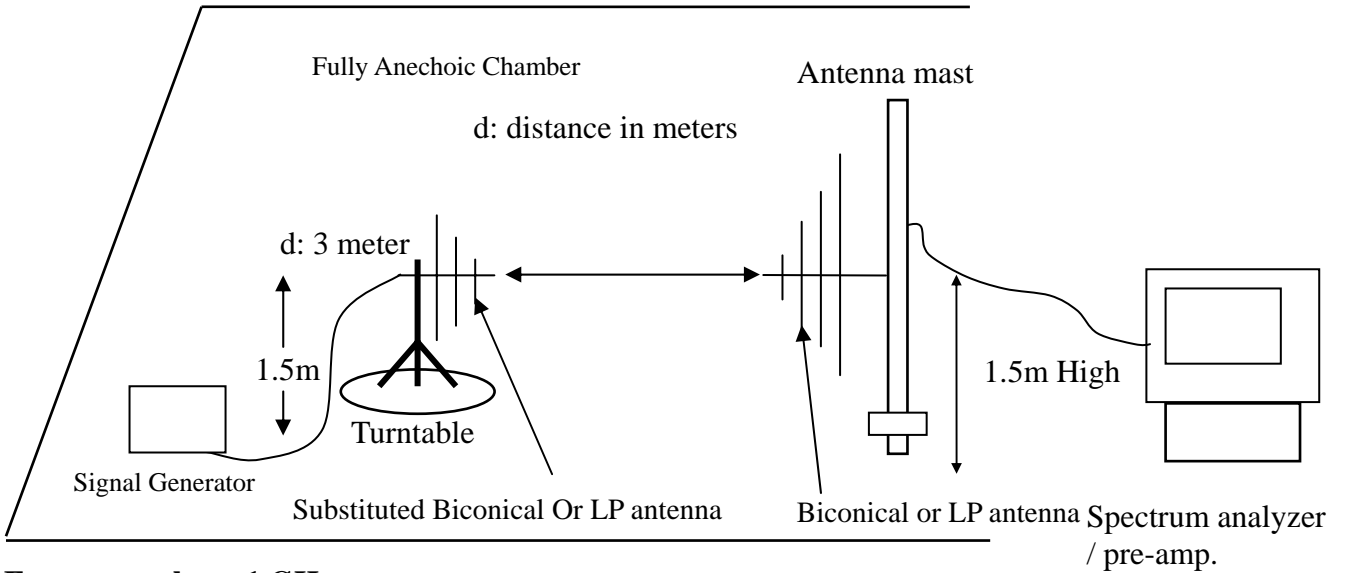

Frequency above 1 GHz

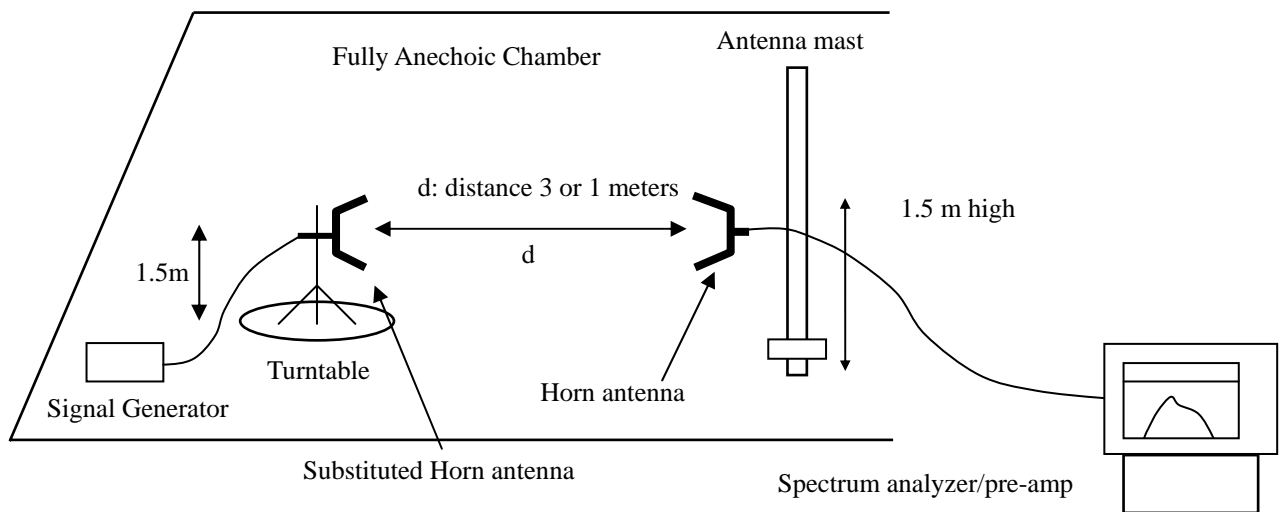

9.4. Test Procedure:

See subclause 5.3 of ETSI EN 300 328 for the test conditions

See Subclause 5.7.5 of ETSI EN 300 328 for transmitter spurious emissions for radiated test method.

The results shown in this test report refer only to the sample(s) tested unless otherwise stated. This test report cannot be reproduced, except in full, without prior written permission of the Company.

9.5. Transmitter Spurious Emissions Test Results: (Radiated)

Ambient temperature: 25 Relative humidity: 65 % Test Date: 04/18/2006

Test Mode: TX CH Low

Freq. (MHz)	SPA. Reading (dBuV)	Ant.Pol. H/V	S.G Output (dBm)	Antenna Gain (dB/dBi)	Cable Loss (dB)	ERP/EIRP (dBm)	Limit (dBm)	Safe Margin (dBm)
30.97	40.84	V	-63.58	-6.89	0.69	-71.16	-36.00	-35.16
320.03	40.97	V	-57.95	-7.81	2.18	-67.94	-36.00	-31.94
499.48	40.77	V	-53.84	-7.72	2.73	-64.29	-36.00	-28.29
4804.00	---	V	---	12.65	9.04	---	-30.00	---
7206.00	---	V	---	11.57	11.21	---	-30.00	---
9608.00	---	V	---	11.97	13.25	---	-30.00	---
12010.00	---	V	---	13.19	15.27	---	-30.00	---
65.89	42.23	H	-69.62	-0.83	0.98	-71.43	-36.00	-35.43
300.63	50.09	H	-49.49	-7.92	1.99	-59.40	-36.00	-23.40
499.48	42.98	H	-50.93	-7.72	2.73	-61.37	-36.00	-25.37
599.39	40.41	H	-51.24	-7.79	2.94	-61.97	-36.00	-25.97
4804.00	---	H	---	12.65	9.04	---	-30.00	---
7206.00	---	H	---	11.57	11.21	---	-30.00	---
9608.00	---	H	---	11.97	13.25	---	-30.00	---
12010.00	---	H	---	13.19	15.27	---	-30.00	---

Measurement uncertainty	+ 1.5dB / -2.5dB < 200MHz
	+ 1.0dB / -1.5dB 1-40GHz

Remark:

- 1 The emission behaviour belongs to narrowband spurious emission.
- 2 Remark”---“ means that the emission level is too low to be measured
- 3 The result basic equation calculation is as follows:
- 4 $ERP/EIRP (dBm) = SG \text{ Setting}(dBm) + Antenna \text{ Gain} (dB/dBi) - Cable \text{ loss} (dB)$

The results shown in this test report refer only to the sample(s) tested unless otherwise stated. This test report cannot be reproduced, except in full, without prior written permission of the Company.

9.6. Transmitter Spurious Emissions Test Results: (Radiated)

Ambient temperature: 25 Relative humidity: 65 % Test Date: 04/18/2006

Test Mode: TX CH Mid

Freq. (MHz)	SPA Reading (dBuV)	Ant.Pol. H/V	S.G Output (dBm)	Antenna Gain (dB/dBi)	Cable Loss (dB)	ERP/EIRP (dBm)	Limit (dBm)	Safe Margin (dBm)
30.97	40.80	V	-63.62	-6.89	0.69	-71.20	-36.00	-35.20
322.94	39.86	V	-58.97	-7.79	2.21	-68.97	-36.00	-32.97
499.48	41.51	V	-53.10	-7.72	2.73	-63.55	-36.00	-27.55
4884.00	---	V	---	12.65	9.12	---	-30.00	---
7326.00	---	V	---	11.53	11.25	---	-30.00	---
9768.00	---	V	---	12.02	13.33	---	-30.00	---
12210.00	---	V	---	13.47	15.37	---	-30.00	---
99.84	43.77	H	-59.44	-7.76	1.22	-68.41	-36.00	-32.41
213.33	48.46	H	-53.10	-7.85	1.68	-62.63	-36.00	-26.63
322.94	50.00	H	-48.49	-7.79	2.21	-58.49	-36.00	-22.49
499.48	43.32	H	-50.59	-7.72	2.73	-61.03	-36.00	-25.03
599.39	41.83	H	-49.82	-7.79	2.94	-60.55	-36.00	-24.55
1741.00	41.03	H	-65.93	9.57	5.22	-61.57	-30.00	-31.57
4884.00	---	H	---	12.65	9.12	---	-30.00	---
7326.00	---	H	---	11.53	11.25	---	-30.00	---
9768.00	---	H	---	12.02	13.33	---	-30.00	---
12210.00	---	H	---	13.47	15.37	---	-30.00	---

Measurement uncertainty	+ 1.5dB / -2.5dB < 200MHz
	+ 1.0dB / -1.5dB 1-40GHz

Remark :

- 1 The emission behaviour belongs to narrowband spurious emission.
- 2 Remark"---" means that the emission level is too low to be measured
- 3 The result basic equation calculation is as follows:
- 4 $ERP/EIRP (dBm) = SG \text{ Setting}(dBm) + Antenna \text{ Gain} (dB/dBi) - Cable \text{ loss} (dB)$

The results shown in this test report refer only to the sample(s) tested unless otherwise stated. This test report cannot be reproduced, except in full, without prior written permission of the Company.

9.7. Transmitter Spurious Emissions Test Results: (Radiated)

Ambient temperature: 25 Relative humidity: 65 % Test Date: 04/18/2006

Test Mode: TX CH High

Freq. (MHz)	SPA. Reading (dBUV)	Ant.Pol. H/V	S.G Output (dBm)	Antenna Gain (dB/dBi)	Cable Loss (dB)	ERP/EIRP (dBm)	Limit (dBm)	Safe Margin (dBm)
65.89	40.79	V	-70.80	-0.83	0.98	-72.61	-36.00	-36.61
320.03	40.03	V	-58.89	-7.81	2.18	-68.88	-36.00	-32.88
499.48	41.16	V	-53.45	-7.72	2.73	-63.90	-36.00	-27.90
4960.00	---	V	---	12.65	9.20	---	-30.00	---
7440.00	---	V	---	11.48	11.29	---	-30.00	---
9920.00	---	V	---	12.07	13.41	---	-30.00	---
12400.00	---	V	---	13.72	15.46	---	-30.00	---
213.33	49.42	H	-52.14	-7.85	1.68	-61.67	-36.00	-25.67
300.63	48.65	H	-50.93	-7.92	1.99	-60.84	-36.00	-24.84
499.48	42.96	H	-50.95	-7.72	2.73	-61.39	-36.00	-25.39
599.39	40.36	H	-51.29	-7.79	2.94	-62.02	-36.00	-26.02
4960.00	---	H	---	12.65	9.20	---	-30.00	---
7440.00	---	H	---	11.48	11.29	---	-30.00	---
9920.00	---	H	---	12.07	13.41	---	-30.00	---
12400.00	---	H	---	13.72	15.46	---	-30.00	---

Measurement uncertainty	+ 1.5dB / -2.5dB < 200MHz
	+ 1.0dB / -1.5dB 1-40GHz

Remark :

- 1 The emission behaviour belongs to narrowband spurious emission.
- 2 Remark"---" means that the emission level is too low to be measured
- 3 The result basic equation calculation is as follows:
- 4 $ERP/EIRP (dBm) = SG \text{ Setting}(dBm) + Antenna \text{ Gain} (dB/dBi) - Cable \text{ loss} (dB)$

The results shown in this test report refer only to the sample(s) tested unless otherwise stated. This test report cannot be reproduced, except in full, without prior written permission of the Company.

9.8. Transmitter Spurious Emissions Test Results: (Radiated)

Ambient temperature: 25 Relative humidity: 65 % Test Date: 04/18/2006

Test Mode: Standby

Freq. (MHz)	SPA. Reading (dBuV)	Ant.Pol. H/V	S.G Output (dBm)	Antenna Gain (dB/dBi)	Cable Loss (dB)	ERP/EIRP (dBm)	Limit (dBm)	Safe Margin (dBm)
30.00	40.90	V	-63.80	-7.34	0.69	-71.83	-57.00	-14.83
300.63	42.83	V	-56.73	-7.92	1.99	-66.64	-57.00	-9.64
497.54	40.22	V	-54.39	-7.72	2.72	-64.83	-57.00	-7.83
1188.50	---	V	---	7.05	4.19	---	-47.00	---
7206.00	---	V	---	11.57	11.21	---	-47.00	---
9608.00	---	V	---	11.97	13.25	---	-47.00	---
12010.00	---	V	---	13.19	15.27	---	-47.00	---
96.93	49.49	H	-53.86	-7.76	1.20	-62.82	-57.00	-5.82
300.63	50.93	H	-48.65	-7.92	1.99	-58.56	-57.00	-1.56
320.03	49.49	H	-49.14	-7.81	2.18	-59.13	-57.00	-2.13
499.48	42.33	H	-51.58	-7.72	2.73	-62.02	-57.00	-5.02
599.39	39.05	H	-52.60	-7.79	2.94	-63.33	-57.00	-6.33
4804.00	---	H	---	12.65	9.04	---	-47.00	---
7206.00	---	H	---	11.57	11.21	---	-47.00	---
9608.00	---	H	---	11.97	13.25	---	-47.00	---
12010.00	---	H	---	13.19	15.27	---	-47.00	---

Measurement uncertainty	+ 1.5dB / -2.5dB < 200MHz
	+ 1.0dB / -1.5dB 1-40GHz

Remark :

- 1 The emission behaviour belongs to narrowband spurious emission.
- 2 Remark”---“ means that the emission level is too low to be measured
- 3 The result basic equation calculation is as follows:
- 4 $ERP/EIRP (dBm) = SG \text{ Setting}(dBm) + Antenna \text{ Gain} (dB/dBi) - Cable \text{ loss} (dB)$

The results shown in this test report refer only to the sample(s) tested unless otherwise stated. This test report cannot be reproduced, except in full, without prior written permission of the Company.

10. ETSI EN 300 328 SUBCLAUSE 4.3.5 RECEIVER SPURIOUS EMISSIONS

10.1. Limit:

The spurious emissions of the receiver shall not exceed the values in tables 3 and 4 in the indicated bands.

Table 3: Narrowband spurious emission limits for receivers

Frequency Range	Limit
30MHz to 1 GHz	-57 dBm
above 1 GHz to 12.75 GHz	-47 dBm

The above limit values apply to narrowband emissions, e.g. as caused by local oscillator leakage. The measurement bandwidth for such emissions may be as small as necessary to get a reliable measurement result.

Wideband emissions shall not exceed the values given in table 4.

Table 4: Wideband spurious emission limits for receivers

Frequency Range	Limit
30MHz to 1 GHz	-107 dBm/Hz
above 1 GHz to 12.75 GHz	-97 dBm/Hz

10.2. Measurement Equipment Used:

Same as section 9.2 in this report.

10.3. Test Setup:

Same as section 9.3 in this report.

10.4. Test Procedure:

See subclause 5.3 of ETSI EN 300 328 for the test conditions

See Subclause 5.7.6 of ETSI EN 300 328 for transmitter spurious emissions for radiated test method.

10.5. Receiver Spurious Emissions Test Results: (Radiated)

Ambient temperature: 25

Relative humidity: 65 %

Test Date: 04/19/2006

Test Mode: RX CH Low

Freq. (MHz)	SPA. Reading (dBuV)	Ant.Pol. H/V	S.G Output (dBm)	Antenna Gain (dB/dBi)	Cable Loss (dB)	ERP/EIRP (dBm)	Limit (dBm)	Safe Margin (dBm)
41.64	40.50	V	-62.15	-2.31	0.80	-65.27	-57.00	-8.27
201.69	42.22	V	-59.83	-7.84	1.58	-69.25	-57.00	-12.25
322.94	40.80	V	-58.03	-7.79	2.21	-68.03	-57.00	-11.03
497.54	38.64	V	-55.97	-7.72	2.72	-66.41	-57.00	-9.41
599.39	37.37	V	-53.15	-7.79	2.94	-63.88	-57.00	-6.88
4804.00	---	V	---	12.65	9.04	---	-47.00	---
7206.00	---	V	---	11.57	11.21	---	-47.00	---
9608.00	---	V	---	11.97	13.25	---	-47.00	---
12010.00	---	V	---	13.19	15.27	---	-47.00	---
65.89	43.20	H	-68.65	-0.83	0.98	-70.46	-57.00	-13.46
300.63	48.44	H	-51.14	-7.92	1.99	-61.05	-57.00	-4.05
322.94	46.73	H	-51.76	-7.79	2.21	-61.76	-57.00	-4.76
499.48	40.72	H	-53.19	-7.72	2.73	-63.63	-57.00	-6.63
599.39	40.88	H	-50.77	-7.79	2.94	-61.50	-57.00	-4.50
4804.00	---	H	---	12.65	9.04	---	-47.00	---
7206.00	---	H	---	11.57	11.21	---	-47.00	---
9608.00	---	H	---	11.97	13.25	---	-47.00	---
12010.00	---	H	---	13.19	15.27	---	-47.00	---

Measurement uncertainty	+ 1.5dB / -2.5dB < 200MHz
	+ 1.0dB / -1.5dB 1-40GHz

Remark :

- 1 The emission behaviour belongs to narrowband spurious emission.
- 2 Remark"---" means that the emission level is too low to be measured
- 3 The result basic equation calculation is as follows:
- 4 $ERP/EIRP (dBm) = SG \text{ Setting}(dBm) + Antenna \text{ Gain} (dB/dBi) - Cable \text{ loss} (dB)$

The results shown in this test report refer only to the sample(s) tested unless otherwise stated. This test report cannot be reproduced, except in full, without prior written permission of the Company.

10.6. Receiver Spurious Emissions Test Results: (Radiated)

Ambient temperature: 25 Relative humidity: 65 % Test Date: 04/19/2006
 Test Mode: RX CH Mid

Freq. (MHz)	SPA. Reading (dBuV)	Ant.Pol. H/V	S.G Output (dBm)	Antenna Gain (dB/dBi)	Cable Loss (dB)	ERP/EIRP (dBm)	Limit (dBm)	Safe Margin (dBm)
65.89	41.50	V	-70.09	-0.83	0.98	-71.90	-57.00	-14.90
300.63	42.03	V	-57.53	-7.92	1.99	-67.44	-57.00	-10.44
499.48	35.87	V	-58.74	-7.72	2.73	-69.19	-57.00	-12.19
4882.00	---	V	---	12.65	9.12	---	-47.00	---
7206.00	---	V	---	11.57	11.21	---	-47.00	---
9608.00	---	V	---	11.97	13.25	---	-47.00	---
12010.00	---	V	---	13.19	15.27	---	-47.00	---
65.89	44.14	H	-67.71	-0.83	0.98	-69.52	-57.00	-12.52
300.63	50.35	H	-49.23	-7.92	1.99	-59.14	-57.00	-2.14
322.94	46.95	H	-51.54	-7.79	2.21	-61.54	-57.00	-4.54
499.48	39.66	H	-54.25	-7.72	2.73	-64.69	-57.00	-7.69
596.48	40.33	H	-51.35	-7.79	2.93	-62.07	-57.00	-5.07
4882.00	---	H	---	12.65	9.12	---	-47.00	---
7206.00	---	H	---	11.57	11.21	---	-47.00	---
9608.00	---	H	---	11.97	13.25	---	-47.00	---
12010.00	---	H	---	13.19	15.27	---	-47.00	---
Measurement uncertainty					+ 1.5dB / -2.5dB < 200MHz			
					+ 1.0dB / -1.5dB 1-40GHz			

Remark :

- 1 The emission behaviour belongs to narrowband spurious emission.
- 2 Remark"---" means that the emission level is too low to be measured
- 3 The result basic equation calculation is as follows:
- 4 $ERP/EIRP (dBm) = SG \text{ Setting}(dBm) + Antenna \text{ Gain} (dB/dBi) - Cable \text{ loss} (dB)$

The results shown in this test report refer only to the sample(s) tested unless otherwise stated. This test report cannot be reproduced, except in full, without prior written permission of the Company.

10.7. Receiver Spurious Emissions Test Results: (Radiated)

Ambient temperature: 25 Relative humidity: 65 % Test Date: 04/19/2006
 Test Mode: RX CH High

Freq. (MHz)	SPA. Reading (dBUV)	Ant.Pol. H/V	S.G Output (dBm)	Antenna Gain (dB/dBi)	Cable Loss (dB)	ERP/EIRP (dBm)	Limit (dBm)	Safe Margin (dBm)
90.14	46.06	V	-58.33	-7.75	1.16	-67.24	-57.00	-10.24
213.33	42.67	V	-59.06	-7.85	1.68	-68.59	-57.00	-11.59
499.48	36.62	V	-57.99	-7.72	2.73	-68.44	-57.00	-11.44
4960.00	---	V	---	12.65	9.20	---	-47.00	---
7440.00	---	V	---	11.48	11.29	---	-47.00	---
9920.00	---	V	---	12.07	13.41	---	-47.00	---
12400.00	---	V	---	13.72	15.46	---	-47.00	---
65.89	44.57	H	-67.28	-0.83	0.98	-69.09	-57.00	-12.09
300.63	49.30	H	-50.28	-7.92	1.99	-60.19	-57.00	-3.19
318.09	45.63	H	-53.10	-7.82	2.16	-63.08	-57.00	-6.08
499.48	39.45	H	-54.46	-7.72	2.73	-64.90	-57.00	-7.90
596.48	41.25	H	-50.43	-7.79	2.93	-61.15	-57.00	-4.15
4960.00	---	H	---	12.65	9.20	---	-47.00	---
7440.00	---	H	---	11.48	11.29	---	-47.00	---
9920.00	---	H	---	12.07	13.41	---	-47.00	---
12400.00	---	H	---	13.72	15.46	---	-47.00	---
Measurement uncertainty				+ 1.5dB / -2.5dB < 200MHz				
				+ 1.0dB / -1.5dB 1-40GHz				

Remark:

- 1 The emission behaviour belongs to narrowband spurious emission.
- 2 Remark”---“ means that the emission level is too low to be measured
- 3 The result basic equation calculation is as follows:
- 4 $ERP/EIRP (dBm) = SG \text{ Setting}(dBm) + Antenna \text{ Gain} (dB/dBi) - Cable \text{ loss} (dB)$

The results shown in this test report refer only to the sample(s) tested unless otherwise stated. This test report cannot be reproduced, except in full, without prior written permission of the Company.

APPENDIX 1

PHOTOGRAPHS OF SET UP

The results shown in this test report refer only to the sample(s) tested unless otherwise stated. This test report cannot be reproduced, except in full, without prior written permission of the Company.

Front of Set up



The results shown in this test report refer only to the sample(s) tested unless otherwise stated. This test report cannot be reproduced, except in full, without prior written permission of the Company.

APPENDIX 2

PHOTOGRAPHS OF EUT

The results shown in this test report refer only to the sample(s) tested unless otherwise stated. This test report cannot be reproduced, except in full, without prior written permission of the Company.

Internal of EUT - 1



Internal of EUT - 2

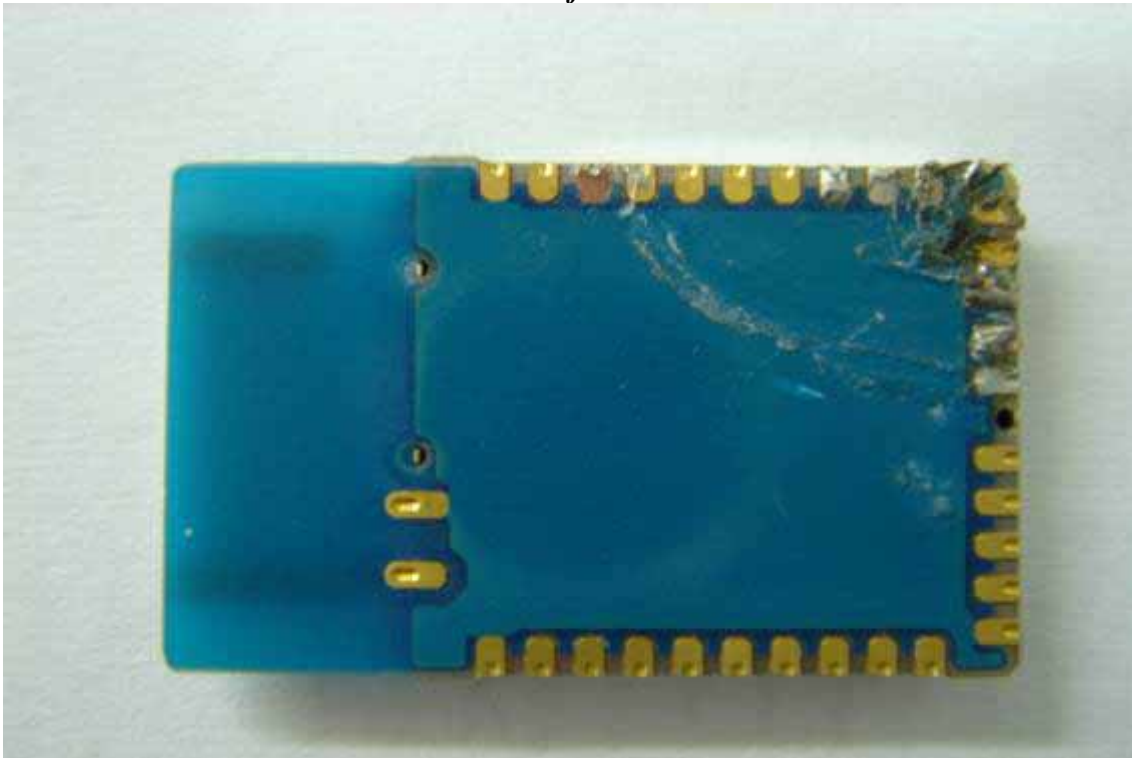

The results shown in this test report refer only to the sample(s) tested unless otherwise stated. This test report cannot be reproduced, except in full, without prior written permission of the Company.

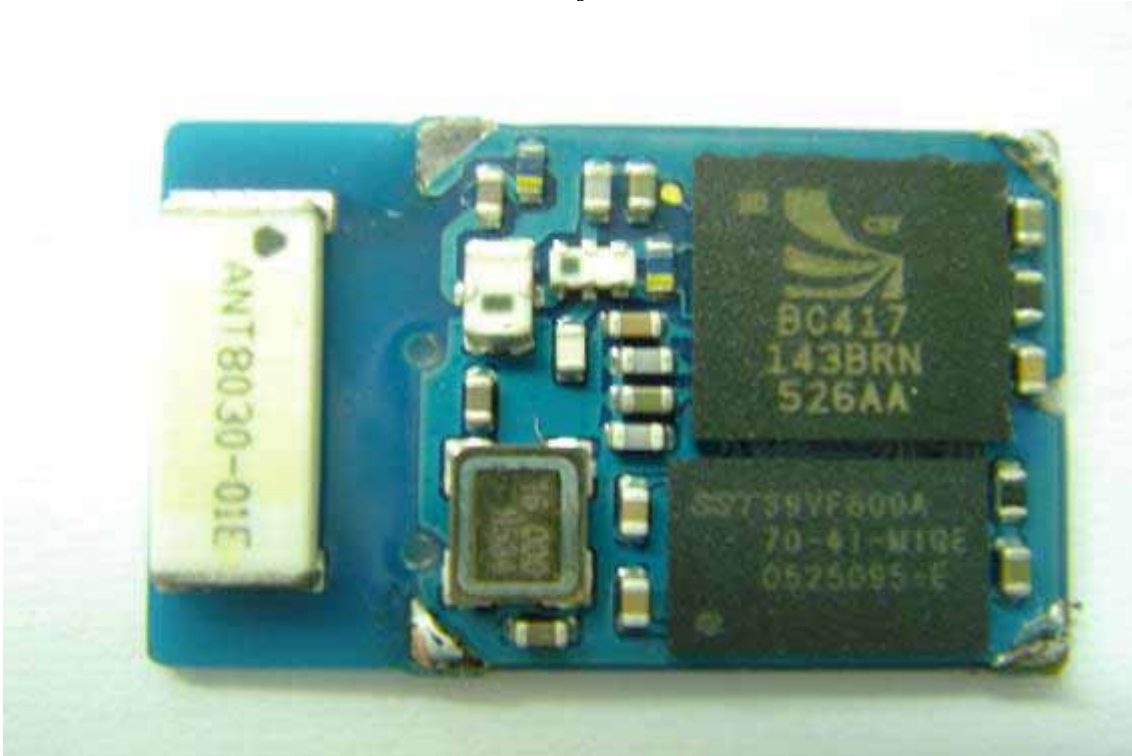
Internal of EUT-3

The results shown in this test report refer only to the sample(s) tested unless otherwise stated. This test report cannot be reproduced, except in full, without prior written permission of the Company.