



Future Technology Devices International Ltd

USB to RS485 Serial Converter Cable

CE FC

Datasheet

Document Reference No.: FT_000117

Version 1.3

Issue Date: 18-12-09

Future Technology Devices International Limited (FTDI)

Unit1, 2 Seaward Place, Centurion Business Park,, Glasgow G41 1HH United Kingdom

Tel.: +44 (0) 141 429 2777 Fax: + 44 (0) 141 429 2758

E-Mail (Support): support1@ftdichip.com Web: <http://www.ftdichip.com>

Copyright © 2010 Future Technology Devices International Limited

Neither the whole nor any part of the information contained in, or the product described in this manual, may be adapted or reproduced in any material or electronic form without the prior written consent of the copyright holder. This product and its documentation are supplied on an as-is basis and no warranty as to their suitability for any particular purpose is either made or implied. Future Technology Devices International Ltd will not accept any claim for damages howsoever arising as a result of use or failure of this product. Your statutory rights are not affected. This product or any variant of it is not intended for use in any medical appliance, device or system in which the failure of the product might reasonably be expected to result in personal injury. This document provides preliminary information that may be subject to change without notice. No freedom to use patents or other intellectual property rights is implied by the publication of this document. Future Technology Devices International Ltd, Unit1, 2 Seaward Place, Centurion Business Park, Glasgow, G41 1HH, United Kingdom. Scotland Registered Number: SC136640

1 Description

The **USB-RS485** cable is a USB to RS485 levels serial UART converter cable incorporating FTDI's FT232RQ USB to serial UART interface IC device which handles all the USB signalling and protocols. The cable provides a fast, simple way to connect devices with a RS485 interface to USB.

Each USB-RS485 cable contains a small internal electronic circuit board, utilising the FT232R, which is encapsulated into the USB connector end of the cable. The FT232R datasheet, [DS_FT232R](http://www.ftdichip.com), is available at <http://www.ftdichip.com>. The integrated electronics also include the RS485 transceiver plus Tx and Rx LEDs which give a visual indication of traffic on the cable (if transparent USB connector specified).

The other end of the cable is bare, tinned wire ended connections by default, but can be customised using different connectors to support various applications.

The USB-RS485 cable is designed for use at the end of an RS485 network up to approximately 10m. For longer networks or placement of the USB-RS485 cable in the middle of an RS485 network it is recommended that the attached wire is cut to 20cm or less to ensure signal integrity

Cables are FCC, CE, RoHS compliant.

The cable is USB powered and USB 2.0 full speed compatible. Each cable is 1.8m long and supports a data transfer rate up to 3 Mbaud. Each cable supports the FTDIChip-ID™, with a unique USB serial number programmed into the FT232R. This feature can be used to create a security or password protected file transfer access using the cable. Further information and examples on this feature are available at <http://www.ftdichip.com> under [FTDIChip-ID Projects](#).

The USB-RS485 cables require USB drivers, available free from <http://www.ftdichip.com>, which are used to make the FT232R in the cable appear as a virtual COM port (VCP). This then allows the user to communicate with the USB interface via a standard PC serial emulation port (for example TTY). Another FTDI USB driver, the D2XX driver, can also be used with application software to directly access the FT232R on the cable through a DLL. This is illustrated in the Figure 1.1

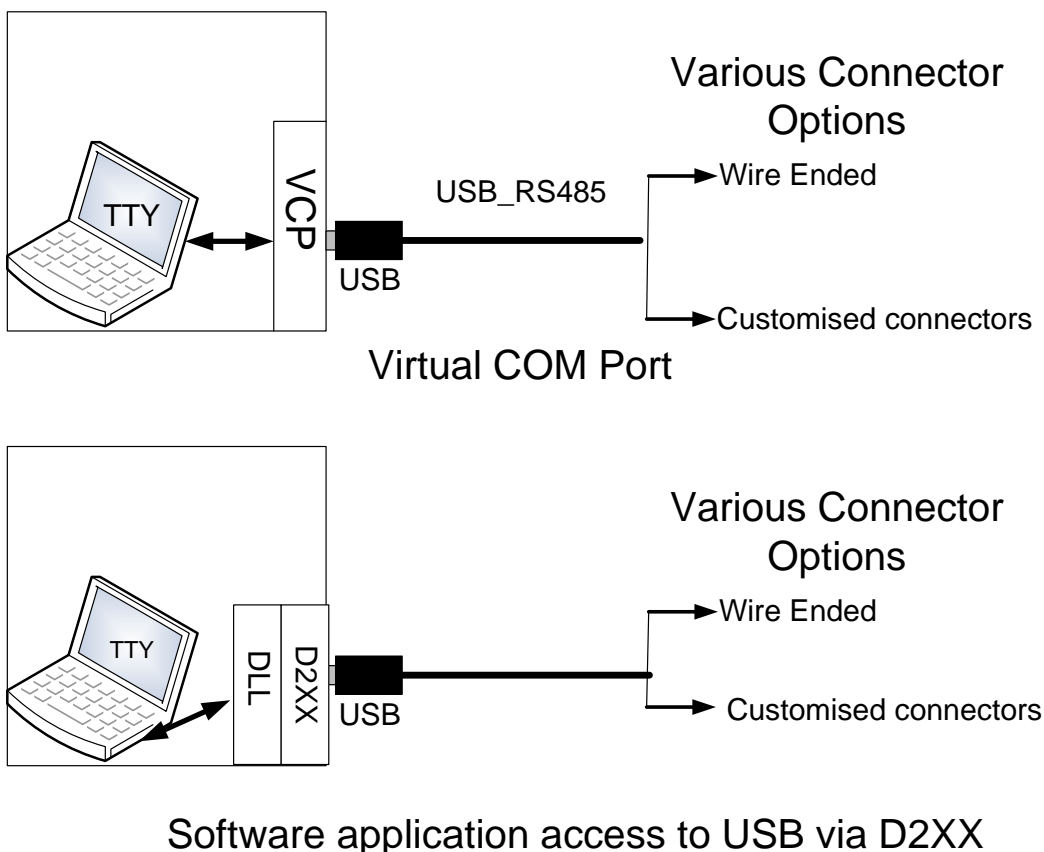

Figure 1.1 Using the USB-RS485 Cable

2 Cable Part Numbers

The following

Table 2.1 gives details of the available USB-RS485 cables.

Part Number	Description	End Connector*	Cable details
USB-RS485-WE-1800-BT	USB to UART cable with RS485 level UART signals. B black cable, T ransparent USB connector	Wire Ended (no connector)	1.8m cable,6 core, UL2464 24 AWG, diam=5mm
* USB-RS485-CC-LLLL-CU-X	USB to UART cable with RS485 level UART signals. C = cable colour (B black or T transparent), U = USB connector colour (T transparent or B black) X = voltage (P is 5V, G is 0V)	CC = Connector description.	LLLL = Length of cable.

Table 2.1 USB-RS485 Cables Descriptions and Part Numbers

* FTDI supports customised end connector designs. For more information, please contact FTDI Sales Team (sales1@ftdichip.com)

2.1 Certifications

FTDI USB-RS485 cable is fully RoHs compliant as well as CE and FCC certified.



Table of Contents

1	Description	1
2	Cable Part Numbers.....	2
2.1	Certifications.....	2
3	Typical Applications.....	4
3.1	Driver Support	4
3.2	Features.....	4
4	Features of FT232R applicable to USB-RS485 Cable	5
5	USB-RS485-WE-LLLL-CU-X	6
5.1	USB-RS485-WE Connections and Mechanical Details.....	6
5.2	USB-RS485-WE Cable Signal Descriptions.....	7
5.3	USB-RS485-WE Electrical Parameters	7
5.4	Local Echo	8
6	Cable PCB Block Diagram.....	9
7	USB-RS485 – Schematic	10
8	Contact Information	11
	Appendix A - Cable EEPROM Configuration.....	13
	Appendix B - List of Figures and Tables.....	14
	Appendix C - Revision History	15

3 Typical Applications

- USB to serial RS485 level converter.
- Upgrading legacy peripherals to USB.
- Interface Microcontroller UART or I/O to USB.
- Interface FPGA or PLD to USB.
- USB Instrumentation PC interface.
- USB industrial control.
- USB password protected file transfers.

3.1 Driver Support

Royalty free VIRTUAL COM PORT (VCP) DRIVERS for...

- Windows 7 64-bit
- Windows XP and XP 64-bit
- Windows Vista and Vista 64-bit
- Windows XP Embedded
- Windows 98, 98SE, ME, 2000, Server 2003, and Server 2008
- Windows CE 4.2, 5.0 and 6.0
- Mac OS 8/9, OS-X
- Linux 2.4 and greater

Royalty free D2XX Direct Drivers (USB Drivers + DLL S/W Interface)

- Windows 7 64-bit
- Windows XP and XP 64-bit
- Windows Vista and Vista 64-bit
- Windows XP Embedded
- Windows 98, 98SE, ME, 2000, Server 2003, and Server 2008
- Windows CE 4.2, 5.0 and 6.0
- Linux 2.4 and greater
- Mac OS-X

The drivers listed above are all available to download for free from www.ftdichip.com. Various 3rd Party Drivers are also available for other operating systems - see www.ftdichip.com for details.

3.2 Features

- USB-RS485 converter cable provides a USB to RS485 serial interface with customised end connectors.
- Entire USB protocol handled by the electronics in the cable.
- EIA/TIA-485 communication interface with low power requirements.
- UART interface support for 7 or 8 data bits, 1 or 2 stop bits and odd / even / mark / space / no parity.
- Internal EEPROM with user writeable area.
- FTDI's royalty-free VCP allow for communication as a standard emulated COM port and D2XX 'direct' drivers provide DLL application programming interface.
- Visual indication of Tx and Rx traffic via LEDs in the transparent USB connector.
- X-On / X-Off software handshaking.
- Data transfer rates from 300 baud to 3 Mbaud.
- Support for FT232R FTDIChip-ID™ feature for improved security.
- Low USB bandwidth consumption.
- UHCI / OHCI / EHCI host controller compatible.
- USB 2.0 Full Speed compatible.
- -40°C to +85°C operating temperature range.
- Cable length is 1.80m (6 feet).
- ESD Protection for RS-485 I/O's
±15kV Human Body Model (HBM)
±15kV EN61000-4-2 Air Gap Discharge
±8kV EN61000-4-2 Contact Discharge
- FCC and CE compliant.
- Custom versions available on request (subject to MOQ).
- RoHS Compliant

4 Features of FT232R applicable to USB-RS485 Cable

The USB-RS485 cable uses FTDI's FT232RQ USB to serial UART IC device. This section summarises the key features of the FT232RQ which apply to the USB-RS485 USB to serial RS485 converter cables. For further details, and a full features and enhancements description consult the FT232R datasheet. This is available from www.ftdichip.com.

Internal EEPROM. The internal EEPROM in each cable is used to store USB Vendor ID (VID), Product ID (PID), device serial number, product description string and various other USB configuration descriptors. Each cable is supplied with the internal EEPROM pre-programmed as described in **Appendix A –Cable EEPROM Configuration**. The internal EEPROM descriptors can be programmed in circuit, over USB without any additional voltage requirement. It can be programmed using the FTDI utility software called MPROG, which can be downloaded from FTDI Utilities on the FTDI website (www.ftdichip.com). Additionally, there is a user area of the internal EEPROM available to system designers to allow storing of data (note that this is not modified by MPROG).

Lower Operating and Suspend Current. The FT232R has a low 15mA operating supply current and a very low USB suspend current of approximately 70µA. (Note that during suspend mode, the current drawn by any customised cable application which uses the USB supply, should not exceed 2.5mA to remain USB compliant)

Low USB Bandwidth Consumption. The USB interface of the FT232R, and therefore the USB-RS485 cables has been designed to use as little as possible of the total USB bandwidth available from the USB host controller.

FTDICHIP-ID™. The FT232R includes the new FTDICHIP-ID™ security dongle feature. This FTDICHIP-ID™ feature allows a unique number to be burnt into each cable during manufacture. This number cannot be reprogrammed. This number is only readable over USB can be used to form the basis of a security dongle which can be used to protect any customer application software being copied. This allows the possibility of using the USB-RS485 cables as a dongle for software licensing. Further to this, a renewable license scheme can be implemented based on the FTDICHIP-ID™ number when encrypted with other information. This encrypted number can be stored in the user area of the FT232R internal EEPROM, and can be decrypted, then compared with the protected FTDICHIP-ID™ to verify that a license is valid. Web based applications can be used to maintain product licensing this way. An application note, AN232R-02, available from FTDI website (www.ftdichip.com) describes this feature.

Improved EMI Performance. The USB-RS485 cables are FCC and CE certified.

Extended Operating Temperature Range - The USB-RS485 cables are capable of operating over an extended temperature range of -40° to +85° C thus allowing them to be used in automotive or industrial applications.

5 USB-RS485-WE-LLLL-CU-X

The USB-RS485-WE cable is un-terminated; it has bare and tinned wires.

The LLLL specifies the length of the cable in cm. The CU specifies the colour of the cable and the colour of the USB connector. The cable can be either Black or transparent. The USB connector comes default as transparent because of LED implemented inside the plug but can be sold in black colour as well. For simplicity, the LLLL and CU have been dropped from the following descriptions.

The cable outputs 5V power on the wire by default. This can be modified to output 0V power. The letter X in the part number indicates the output power selection.

5.1 USB-RS485-WE Connections and Mechanical Details

The following **Figure 5.1** shows the cable signals and the wire colours for the signals on the USB-RS485-WE cable.

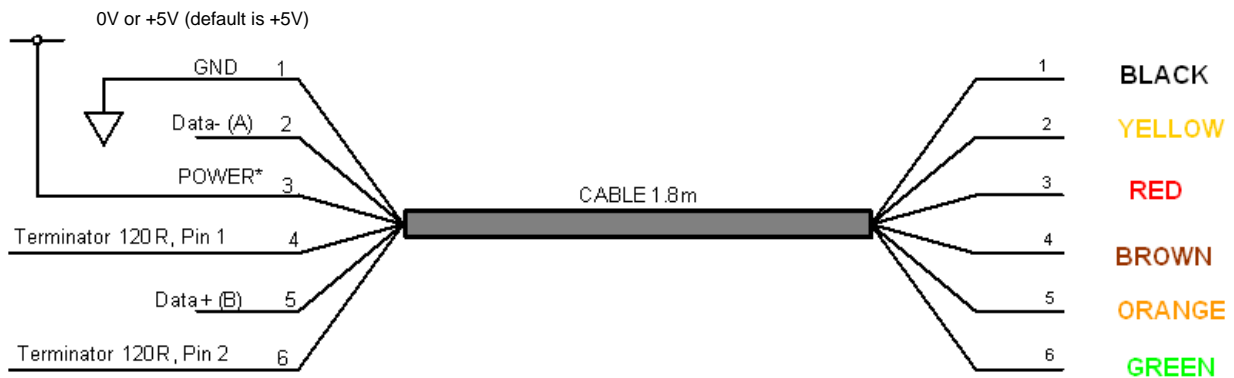

Figure 5.1 USB-RS485-WE Connections

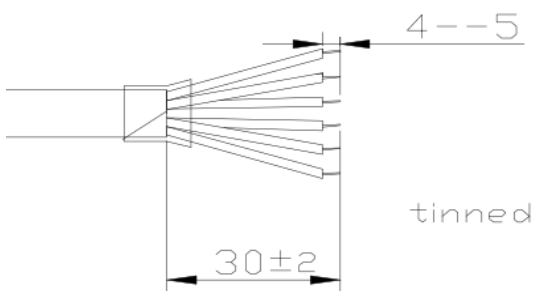

Figure 5.2 USB-RS485-WE Mechanical Details (dimensions in mm)



Figure 5.3 USB-RS485-WE Cable images

5.2 USB-RS485-WE Cable Signal Descriptions

Colour	Name	Type	Description
Black	GND	GND	Device ground supply pin.
Brown	Terminator 1	Input	Pin 1 of 120R Terminating Resistor. Only Required if the USB-RS485-WE cable is the first or last device in a multi-drop RS485 System, to meet RS485 Termination Requirements.
Red	POWER	Output	Default output is +5V when active, 0V during suspend. Power output can be customized to 0V, if required, contact FTDI Sales Team (sales1@ftdichip.com). Switchable power to external device, 250mA max. OFF during suspend
Orange	Data+ (B)	Bi-Direction	Data + (B) Signal
Yellow	Data- (A)	Bi-Direction	Data - (A) Signal
Green	Terminator 2	Input	Pin 2 of 120R Terminating Resistor. Only Required if the USB-RS485-WE cable is the first or last device in a multi-drop RS485 System, to meet RS485 Termination Requirements.

Table 5.1 USB-RS485-WE Cable Signal Descriptions

5.3 USB-RS485-WE Electrical Parameters

Parameter	Description	Minimum	Typical	Maximum	Units	Conditions
VCC_5V	Output Power Voltage*	4.25	5.0*	5.25	V	This only applies when cable has been configured to output 5V. The range is dependent on the USB port that the USB-RS485-WE is connected to
I _o	Output Power Current***	-		250	mA	Must be less than 2.5mA during suspend.
T	Operating Temperature Range	-40		+85	°C	

Table 5.2 USB-RS485-WE I/O Operating Parameters

*Default is 5V.

***Only applies when POWER output is 5V.

Parameter	Description	Minimum	Typical	Maximum	Units	Conditions
Receiver Input						
VCM	Common-mode input voltage range	-7		+12	V	
IN	Input Current			1.0	mA	VIN = +12V
				-0.8		VIN = -7V
VTH	Differential Threshold Voltage, VTH	-0.2		+0.2	V	
VIHYST	Input Hysteresis		20		mV	
RIN	Input Resistance, RIN	12	15		kΩ	
Transmitter Output						
VOD	Differential Output Voltage, dVOD	1.5		5	V	With RL = 54Ω. CL = 50pF *

Table 5.3 USB-RS485-WE I/O Pin Characteristics

* - The 54 ohms is the equivalent of two 120 ohm termination resistors placed on each side of the transmission line and the input impedance of 32 receivers on the line.

Description	Conditions	Minimum	Typical	Maximum
ESD HBM	RS-485 Inputs and Outputs		±15 kV	
EN61000-4-2ContactDischarge	RS-485 Inputs and Outputs		±8 kV	
EN61000-4-2AirGapDischarge	RS-485 Inputs and Outputs		±15 kV	

Table 5.4 USB-RS485-WE ESD Tolerance

5.4 Local Echo

RS485 systems often have local echo enabled. This means any data transmitted by a device is echoed back to itself.

The USB-RS485-WE cable allows for local echo to be enabled/disabled by changing a bit in the FT232R EEPROM. If CBUS4 in the EEPROM is set for "PWRON#" local echo is enabled. If CBUS4 in the EEPROM is set for "TXDEN" local echo is disabled.

Users can set this with MPROG from www.ftdichip.com

The default for the local echo is disabled (CBUS4 set for "TXDEN").

6 Cable PCB Block Diagram

The block diagram for the small internal electronic circuit board, utilising the FTDI FT232R, which is encapsulated into the USB connector end of the cable, is shown in Figure 6.1.

Customised versions of the cable are also available. Users interested in customised versions of these cables should contact FTDI sales (sales1@ftdichip.com).

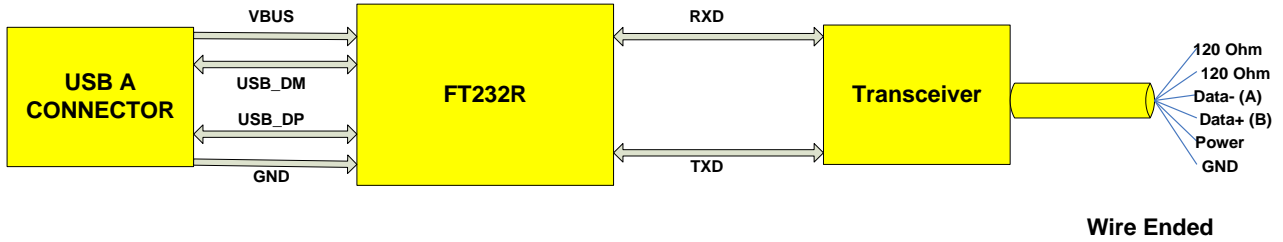

Figure 6.1 Block diagram of PCB Used in the USB to RS485 Serial Converter Cable

7 USB-RS485 – Schematic

Schematic for converter cable, USB-RS485 is shown below in figure 7.1

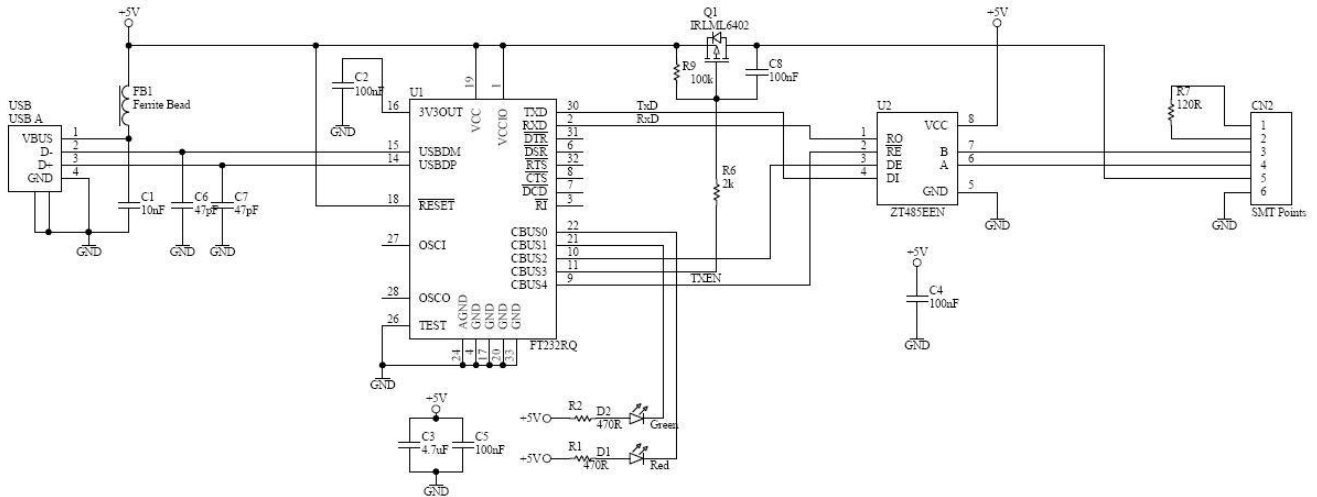

Figure 7.1 Schematic of USB-RS485 Converter Cable

8 Contact Information

Head Office – Glasgow, UK

Future Technology Devices International Limited
Unit 1, 2 Seaward Place, Centurion Business Park
Glasgow G41 1HH
United Kingdom
Tel: +44 (0) 141 429 2777
Fax: +44 (0) 141 429 2758

E-mail (Sales) sales1@ftdichip.com
E-mail (Support) support1@ftdichip.com
E-mail (General Enquiries) admin1@ftdichip.com
Web Site URL <http://www.ftdichip.com>
Web Shop URL <http://www.ftdichip.com>

Branch Office – Shanghai, China

Future Technology Devices International Limited (China)
Room 408, 317 Xianxia Road,
ChangNing District,
ShangHai, China

Tel: +86 (21) 62351596
Fax: +86(21) 62351595

E-Mail (Sales): cn.sales@ftdichip.com
E-Mail (Support): cn.support@ftdichip.com
E-Mail (General Enquiries): cn.admin1@ftdichip.com
Web Site URL: <http://www.ftdichip.com>

Branch Office – Taipei, Taiwan

Future Technology Devices International Limited (Taiwan)
2F, No. 516, Sec. 1, NeiHu Road
Taipei 114
Taiwan , R.O.C.
Tel: +886 (0) 2 8791 3570
Fax: +886 (0) 2 8791 3576

E-mail (Sales) tw.sales1@ftdichip.com
E-mail (Support) tw.support1@ftdichip.com
E-mail (General Enquiries) tw.admin1@ftdichip.com
Web Site URL <http://www.ftdichip.com>

Branch Office – Hillsboro, Oregon, USA

Future Technology Devices International Limited (USA)
7235 NW Evergreen Parkway, Suite 600
Hillsboro, OR 97123-5803
USA
Tel: +1 (503) 547 0988
Fax: +1 (503) 547 0987

E-Mail (Sales) us.sales@ftdichip.com
E-Mail (Support) us.admin@ftdichip.com
Web Site URL <http://www.ftdichip.com>

Distributor and Sales Representatives

Please visit the Sales Network page of the FTDI Web site for the contact details of our distributor(s) and sales representative(s) in your country.

Vinculum is part of Future Technology Devices International Ltd. Neither the whole nor any part of the information contained in, or the product described in this manual, may be adapted or reproduced in any material or electronic form without the prior written consent of the copyright holder. This product and its documentation are supplied on an as-is basis and no warranty as to their suitability for any particular purpose is either made or implied. Future Technology Devices International Ltd will not accept any claim for damages howsoever arising as a result of use or failure of this product. Your statutory rights are not affected. This product or any variant of it is not intended for use in any medical appliance, device or system in which the failure of the product might reasonably be expected to result in personal injury. This document provides preliminary information that may be subject to change without notice. No freedom to use patents or other intellectual property rights is implied by the publication of this document. Future Technology Devices International Ltd, Unit 1, 2 Seaward Place, Centurion Business Park, Glasgow G41 1HH United Kingdom. Scotland Registered Number: SC136640

Appendix A - Cable EEPROM Configuration

Each USB-RS485 cable is controlled by the FTDI FT232R IC. This FT232R device contains an EEPROM which contains the USB configuration descriptors for that device. When the cable is plugged into a PC or a USB reset is performed, the PC will read these descriptors. The default values stored into the internal EEPROM are defined in Table 0.1

Parameter	Value	Notes
USB Vendor ID (VID)	0403h	FTDI default VID (hex)
USB Product ID (PID)	6001h	FTDI default PID (hex)
Serial Number Enabled?	Yes	
Serial Number	See Note	A unique serial number is generated and programmed into the EEPROM during device final test.
Pull down I/O Pins in USB Suspend	Disabled	Enabling this option will make the device pull down on the UART interface lines when the power is shut off (PWREN# is high).
Manufacturer Name	FTDI	
Product Description	See note	USB-RS485-WE
Max Bus Power Current	250mA	
Power Source	Bus Powered	
Device Type	FT232R	
USB Version	0200	Returns USB 2.0 device description to the host. Note: The device is a USB 2.0 Full Speed device (12Mb/s) as opposed to a USB 2.0 High Speed device (480Mb/s).
Remote Wake Up	Disabled	
High Current I/Os	Enabled	Enables the high drive level on the UART and CBUS I/O pins.
Load VCP Driver	Enabled	Makes the device load the VCP driver interface for the device.
Invert TXD	Disabled	Signal on this pin becomes TXD# if enable.
Invert RXD	Disabled	Signal on this pin becomes RXD# if enable.
Invert RTS#	Disabled	Signal on this pin becomes RTS if enable.
Invert CTS#	Disabled	Signal on this pin becomes CTS if enable.

Table 0.1 Default Internal EEPROM Configuration

The internal EEPROM in the cable can be re-programmed over USB using the utility program MPROG. MPROG can be downloaded from the www.ftdichip.com. Version 2.8a or later is required for the FT232R chip. Users who do not have their own USB Vendor ID but who would like to use a unique Product ID in their design can apply to FTDI for a free block of unique PIDs. Contact FTDI support for this service.

Appendix B - List of Figures and Tables

List of Figures

Figure 1.1 Using the USB-RS485 Cable.....	1
Figure 5.1 USB-RS485-WE Connections	6
Figure 5.2 USB-RS485-WE Mechanical Details (dimensions in mm)	6
Figure 5.3 USB-RS485-WE Cable images.....	6
Figure 6.1 Block diagram of PCB Used in the USB to RS485 Serial Converter Cable	9
Figure 7.1 Schematic of USB-RS485 Converter Cable	10

List of Tables

Table 2.1 USB-RS485 Cables Descriptions and Part Numbers.....	2
Table 5.1 USB-RS485-WE Cable Signal Descriptions.....	7
Table 5.2 USB-RS485-WE I/O Operating Parameters.....	7
Table 5.3 USB-RS485-WE I/O Pin Characteristics	8
Table 5.4 USB-RS485-WE ESD Tolerance.....	8
Table 0.1 Default Internal EEPROM Configuration.....	13

Appendix C - Revision History

Version Draft	First Draft	Jan, 2009
Version 1.0	First Release	11 th Feb, 2009
Version 1.1	Added and corrected images	14 th May 2009
Version 1.2	Corrected default state of the power pin Added Windows 7 64-bit	
	Added Description – Length of the cable/wire recommendations	29 th October 2009
Version 1.3	Changed TT to BT (Transparent to Black cable)	18 th December 2009