

BlueStamp® Module

BR-SC40N Class1, 2, and 3 Bluetooth® ver2.0

OUTLINE

- **AT HOME. AT WORK. ON THE ROAD. USING BLUETOOTH WIRELESS TECHNOLOGY MEANS TOTAL FREEDOM FROM THE CONSTRAINTS AND CLUTTER OF WIRES IN YOUR LIFE.**
- Wireless communications module certified to *Bluetooth®* ver2.0.
- With Female Reverse SMA RF board connector. Optional male SMA 1/2 wave coaxial dipole external swivel antenna available.
- Conforms to FCC, IC, CE, and EMI standards of each country.
- UART data interface (2-wire or 4-wire with CTS/RTS).
- 13-bit PCM, 8k samples/s, synchronous bidirectional audio interface
- Includes integrated software stack, profiles, and AT modem like commands.
- Embedded *Bluetooth* Stack Profiles Included (*requires no host MCU stack*): SPP, DUN, LAN, Headset, HFP, eSCO, SCO, Audio Gateway, FTP Client/Server, OBEX, OPP – Push/Pull, GAP, SDP, RFCOMM, and L2CAP protocols.



FEATURES

- The *BlueStamp* serial radio modems can be configured, commanded, and controlled through simple ASCII strings over the *Bluetooth* RF link or directly through the hardware serial UART.
- Dedicated PCM voice channel for audio applications, and eSCO for exceptional audio clarity
- UART baud rate speeds: 1200bps up to 921.6Kbps, and customized
- +200 meter (660 feet) distance
- Software adjustable transmitter power from short to long range applications
- Low power consumption (*80mA TX, 40mA RX, 1.4mA idle mode, and 30uA deep sleep*)
- Small-form factor 18 Pin DIP radio modem package (0.1" pitch X 0.8" socket width)
- Operating temperature range: -40~+70°C.
- Secure and robust communication link
 - ✓ FHSS (Frequency Hopping Spread Spectrum)
 - ✓ Encryption and 16 alphanumeric Personal Identification Number (PIN)
 - ✓ Error correction schemes for guaranteed packet delivery

SPECIFICATIONS

Item	Specifications
Frequency	2402 ~ 2480MHz
Modulation	FHSS/GFSK
Channel intervals	1MHz
Number of channels	79CH
Power supply voltage	3.3Vdc ± 0.1V and 10mVp-p max. noise
Current consumption	120mA worst case peak
Transmission rate (over the air)	721kbps
Receive sensitivity	-83dBm typ.
Output level (variable)	12dBm max.
Dimensions	
	Main PCB

BlueStamp® Module

PIN DEFINITIONS

 **BR-SC40N (With External SMA Antenna)** *make from BR-C40N*

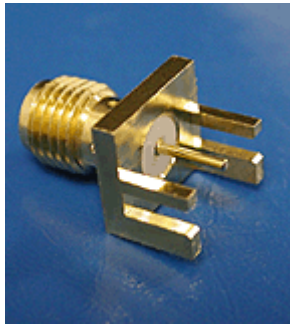

BR-RF-SMA (Available from [BlueRadios](#))

Note: SPI is for BlueRadios internal use only.
Part is not 5Vdc tolerant.

Reset is active **low**; pulse >5msec.

PIO Sink Current is 4mA max.

Unused pins can float except for PIO(4), tie to ground if not used or disable via software.

Firmware Options

- **AT Command**
 - Multi-point
 - Point-to-point
 - Repeater
- **HCI or BCSP**
- **Custom**

BR-SC40N (DIP) <i>BlueStamp</i>	BR-C40N (SMT) <i>BlueRadios</i>	Misc. Info.
1. GND	1. GND	All Connected
2. SPI_MOSI	2. SPI_MOSI	Reserved
NC	3. PIO[6]	
NC	4. PIO[7]	
3. RESET	5. RESET	
4. SPI_CLK	6. SPI_CLK	Reserved
5. PCM_CLK	7. PCM_CLK	
6. PCM_SYNC	8. PCM_SYNC	
7. PCM_IN	9. PCM_IN	
8. PCM_OUT	10. PCM_OUT	
9. VDD (3.3Vdc)	11. VDD (3.3Vdc)	±0.1Vdc, max. 10mVpp ripple
GND	12. GND	
10. UART_RX	13. UART_RX	0-3.3Vdc logic levels
11. UART_TX	14. UART_TX	0-3.3Vdc logic levels
12. UART_RTS	15. UART_RTS	0-3.3Vdc logic levels
13. UART_CTS	16. UART_CTS	0-3.3Vdc logic levels
NC	17. Not Used	USB_D+
NC	18. Not Used	USB_D-
14. PIO[2]	19. PIO[2]	Bluetooth Connection
NC	20. PIO[3]	
15. PIO[5]	21. PIO[5]	Radio Status
16. PIO[4]	22. PIO[4]	Factory Default Reset
17. SPI_CSB	23. SPI_CSB	Reserved
18. SPI_MISO	24. SPI_MISO	Reserved
GND	25. GND	
NC	26. NC	
1.	27. GND	
1.	28. GND	
1.	29. GND	

*For technical details of the products in this page, refer to Sales Dept., BlueRadios, Inc.

BlueStamp™ Module

STANDARD PIN DIMENSIONS

● **BR-SC40N (With External SMA Antenna)** *make from BR-C40N*

The **BlueStamp®** design already includes a RF ground plane and female SMA board edge PCB RF Connector.

18 Pin DIP (Through-hole)
0.1" Pitch and 0.8" Wide Socket

Note: Keep metallic components and connectors from the antenna area.

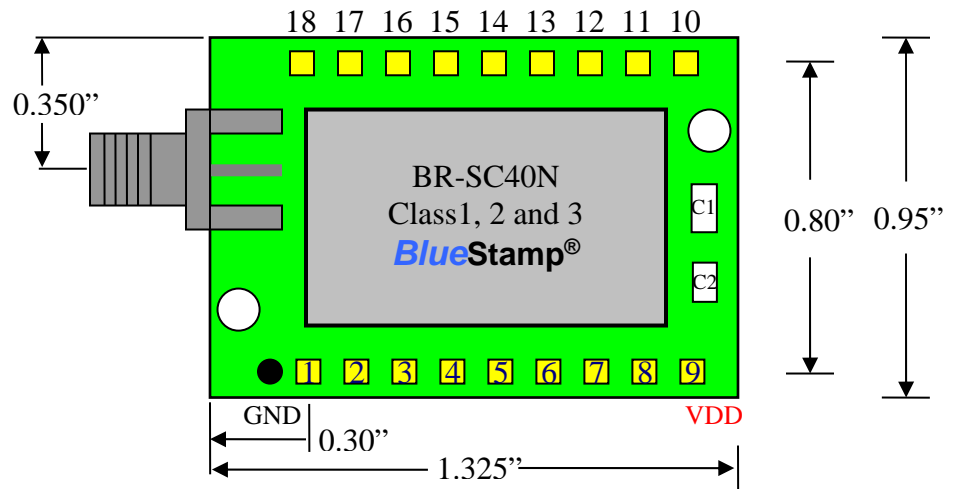

External power supply decoupling capacitors C1 and C2 are optional. C1 = 10uf Capacitor, 0805 Ceramic
C2 = 0.1uf Capacitor, 0603 Ceramic

Power-up Sequence

The unit must be reset with pin 3 "RESET" after turning on the power supply VDD. Reset terminal should be **low** for >5 msec. to cause a reset incase of electrical "brown-out" or poor input supplied VDD. Allow 1sec for module to fully reboot. Unit will not initially boot-up reliably if the VDD ramp rate is in milliseconds.

Please refer to BlueRadios Specification BR-AT_COMMANDS-100 hardware and software interface definition.

BlueStamp® Module

BOARD SCHEMATIC

BR-SC40N (With External SMA Antenna) *make from BR-C40N*

